

**INSTALLATION INSTRUCTION**  
**ISTRUZIONI DI MONTAGGIO**  
**INSTALLATIONSANLEITUNG**  
**INSTRUCTIONS D'INSTALLATION**  
**INSTRUCCIONES DE MONTAJE**

**ZERO 33**  
**EVO 48V TRACK**

Art.

9648

9649

48V Low Voltage Track Lighting

Lampada per binari a basso voltaggio 48V

48V Low-Voltage-Schienensysteme Leuchten

Éclairage de voie basse tension 48V

Luminarias de pista de bajo voltage 48V

For Art. 9648

For Art.9649

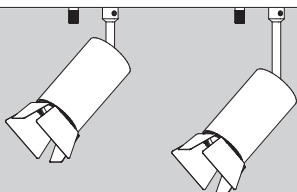

**CAUTIONS**

**AVVERTENZE, WARNUNG**  
**PRECAUTIONS, PRECAUCIONES**

1. Switch-off the power supply before any installation and maintenance operations.  
Use only a two-pole switch

Staccare la linea elettrica prima dell'installazione e di ogni intervento di manutenzione.  
Utilizzare un interruttore bipolare

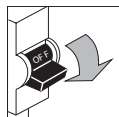

Die Stromzufuhr muss vor der Installation /  
Wartung ausgechaltet werden.  
Nur mit einen zweipoligen Stecker zu verwenden

Couper la source d'alimentation avant toute  
installation et opération d'entretien.  
Seulement utiliser avec un connecteur bipolaires

No efectuar la conexión de la lámpara con la  
tensión general activada.  
Usar un interruptor bipolar

2. Installation must be carried out only by qualified personnel according to safety norms and local regulations.

L'installazione deve essere effettuata da  
personale qualificato secondo la normativa  
elettrica vigente.

Die Installation muss nach den gültigen  
Sicherheitsvorschriften durch einen  
konzessionierten Elektroinstallateur erfolgen.

L'installation doit être réalisée par un électricien  
qualifié en respectant les prescriptions en  
vigueur.

La instalación debe ser realizada por una  
persona cualificada y de acuerdo a la normativa  
vigente.

3. Use this light fixture at the rated voltage and frequency as indicated on the specification table.

Utilizzare questo apparecchio a tensione e  
frequenza indicate nella tabella.

Die Leuchte darf nur mit der angegebenen  
Spannung und Frequenz betrieben werden.

Respecter les prescriptions de tension et de  
fréquence indiquées dans le tableau final.

Utilice esta lámpara a la tensión y frecuencia  
indicadas en las instrucciones.

4. This installation manual must be retained by the person responsible for the installation and maintenance of the product.

Queste istruzioni di montaggio devono essere  
conservate dal responsabile dell' installazione e  
manutenzione dell' apparecchio.

Bewahren Sie diese Gebrauchsanweisung für den  
verantwortlichen Benutzer / Wartungstechniker  
auf.

Gardez cette instruction pour l'utilisateur /  
technicien de maintenance.

Estas instrucciones deben ser conservadas  
por el responsable de mantenimiento de la  
instalación.

# INSTALLATION

## INSTALLAZIONE, MONTAGE, INSTALLATION, INSTALACIÓN

1

### Track Type Compatibility

Tipi di binari compatibili, Stromschienen Type-Kompatibilität  
Compatibilitat des types de pistes, Compatibilidad con el tipo de pista

**For Art.9648  
Zero 33 EVO 48V**

Surface Track  
**2ST1**



Surface Track  
Pendant Track  
**2ST6**



Deep Pendant Track  
For Down  
**2ST9**

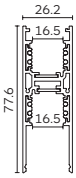

Pendant Track  
For Down  
**2ST7**

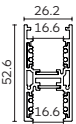

Recessed Track  
Trim  
**2ST8**



Recessed Track Trimless  
**2ST3**



**For Art.9649  
Zero 33 EVO 48V  
with Long Arm**

Deep Surface Track  
Deep Pendant Track  
**2ST2**

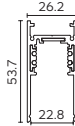

Deep Pendant Track  
For Up & Down  
**2ST9**

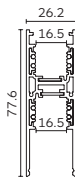

Deep Recessed Track  
Trimless  
**2ST5**

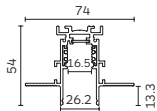

Deep Recessed Track  
Trimless  
**2STA**

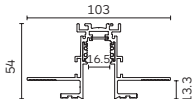

2

For Art.9648

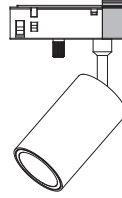

For Art.9649



3

**When the fixture turns automatically,  
need to lock the screw on the adapter.**

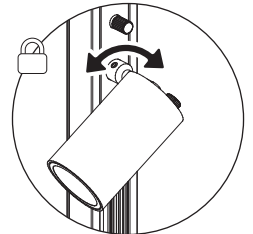
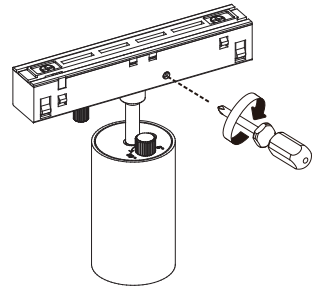

4

positive and negative reversible

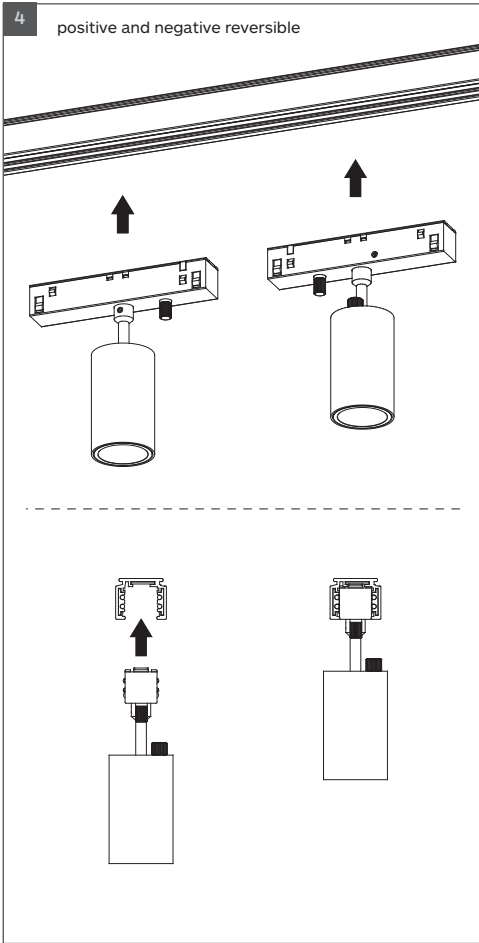

5

Zoomable Lens System

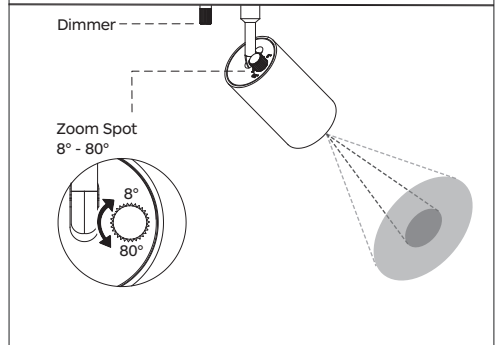

### ANGLE ADJUSTMENT

ORIENTAMENTO DEL VANO OTTICO,  
 ORIENTUNG DER OPTISCHEN,  
 ORIENTATION DU GROUPE OPTIQUE,  
 ORIENTABILIDAD DE LA OPTICA

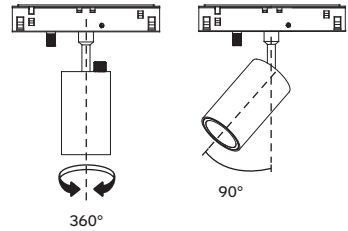

### ACCESSORIES

ACCESSORIO, ZUBEHÖR  
 ACCESSOIRES, ACCESORIOS

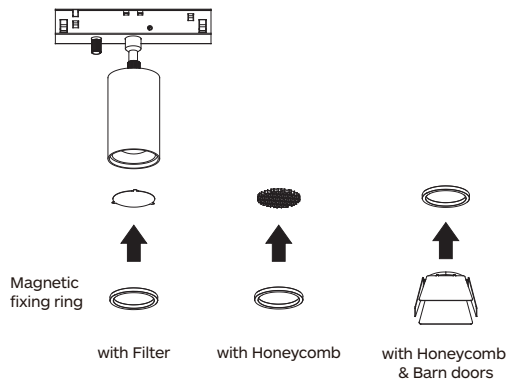

## MEASUREMENTS

DIMENSIONI, ABMESSUNGEN,  
DIMENSIONS, MEDIDAS

in mm

Zero 33

Art.: 9648

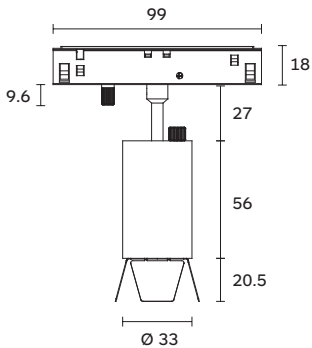

Zero 33 Long Arm

Art.: 9649

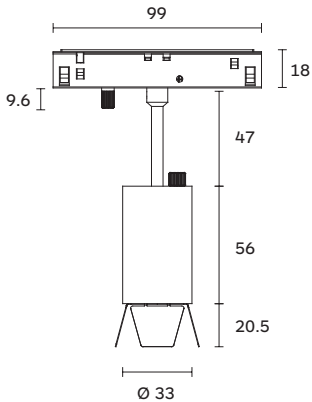

## SPECIFICATION

CARATTERISTICHE, BESCHREIBUNG,  
CARACTERISTIQUES, ESPECIFICACIONES

Art.	Max Wattage(W)	Voltage (V)	Lamp	Remarks	Class
9648	6.5W	48	LED	*	
9649	6.5W	48	LED	*	

- \* LED and LED driver included.  
LED e alimentatore compresi.  
Inklusive LED und LED Driver.  
LED et driver LED inclus.  
LED y alimentador incluidos.

For LED replacement, please contact us.

Per rimpiazzare il LED, la preghiamo di contattarci.

Pour le remplacement de LED, s'il vous plait contactez-nous.

Zum Austausch des LEDs, bitte setzen Sie in Verbindung mit uns.

Para reemplazar el LED, por favor contacte con nosotros.



**formalighting**

**Forma Lighting (Italia) S.r.l.**

T: (+39) 02 9354 0300

F: (+39) 02 9343 5117

E: [formaitalia@formalighting.it](mailto:formaitalia@formalighting.it)

Address: Via Europa, 35/A

20005 Pogliano Mil.se MI

**Forma Lighting (HK) Ltd.**

T: (+852) 2516 6500

F: (+852) 2516 6525

E: [forma@forma.com.hk](mailto:forma@forma.com.hk)

Address: Room 4, 5/F.,

Eastern Harbour Centre

28 Hoi Chak Street

Quarry Bay, Hong Kong

