



formalighting

**EVO**

**48V Track System**

**2026**

# **EVO 48V Track System**

Page 16

# Viivo

Page 24

# TicTok

Page 32

# Zero

Page 44

# Polaris

Page 50

# Filo

Page 56

# PiXXo Retro

Page 58

# PiXXo

Page 60

# Lucciole

## Viivo



**Viivo & Viivo Zoom**

Page 16 & Page 20

Ø 75

Ø 58

Ø 45

Ø 35

Ø 25

Ø 75

Ø 58

Ø 45

**Long Arm**

**Viivo**

Page 18

Ø 75

Ø 58

Ø 45

Ø 35

Ø 25

**Viivo  
Top Mounted**

Page 22

Ø 75

Ø 58

Ø 45

# TicTok



**TicTok**

Page 24



**TicTok Zoom**

Page 28

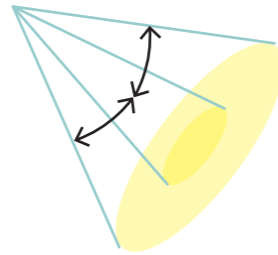

Ø 75



Ø 75



Ø 58



Ø 45



Ø 58



Ø 45



Ø 35



**TicTok Top Mounted**

Page 30



Ø 25



Ø 75



**Long Arm**



**TicTok**

Page 26

Ø 58



Ø 45



Ø 75



Ø 58



Ø 45



Ø 35



Ø 25



**Long Arm**



**TicTok Zoom**

Page 28

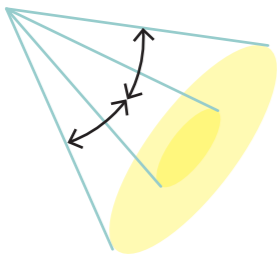

Ø 75



Ø 58



Ø 45



# Zero Framing Projector



**Zero 28 Framing Projector**

Page 32



Ø 28



**Zero 38 Framing Projector**

Page 34



Ø 38

**Long Arm**



**Zero 38 Framing Projector**

Page 34



Ø 38

# Zero

**Zero  
Compasso  
Wallwasher**

Page 36



**Zero 33**

Page 40

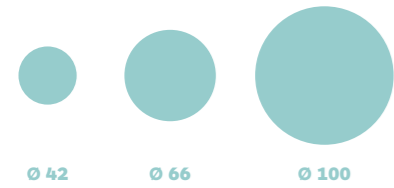

Ø 42

Ø 66

Ø 100

**Long Arm**

**Zero**

Page 42

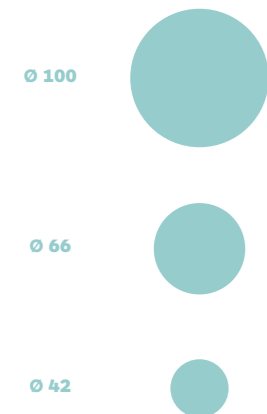

Ø 100

Ø 66

Ø 42

# Polaris



**Long Arm**

**Zero  
Compasso  
Wallwasher**

Page 36



**Zero 33**

Page 40

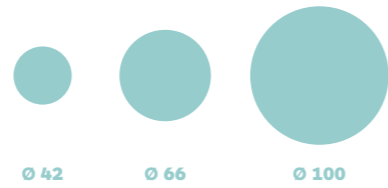

Ø 42

Ø 66

Ø 100



**Zero**

Page 42



Ø 100

Ø 66

Ø 42



**Polaris 20**

Page 52

**Polaris 20**

Page 44

**Polaris 20 Wallwasher**

Page 44

**Polaris 20 Adjustable**

Page 48



**Polaris 20 Opal Diffuser**

Page 46

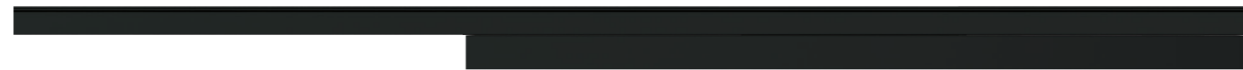



# Filo

Page 50

# Pixxo

Page 58

# Pixxo Retro

Page 56



Ø 38



Ø 38

Ø 25



Ø 25

# Lucciole

Page 60



# EVO 48V Track Options

Pages 68-71

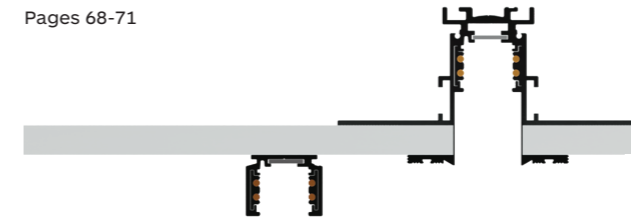

# Power Supply

Page 80



# Mounting Accessories

Page 68

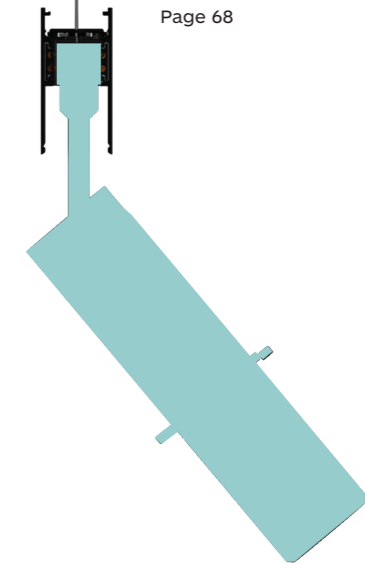

# Code Ordering System

Page 85

# EVO 48V Track, High Performance Luminaires

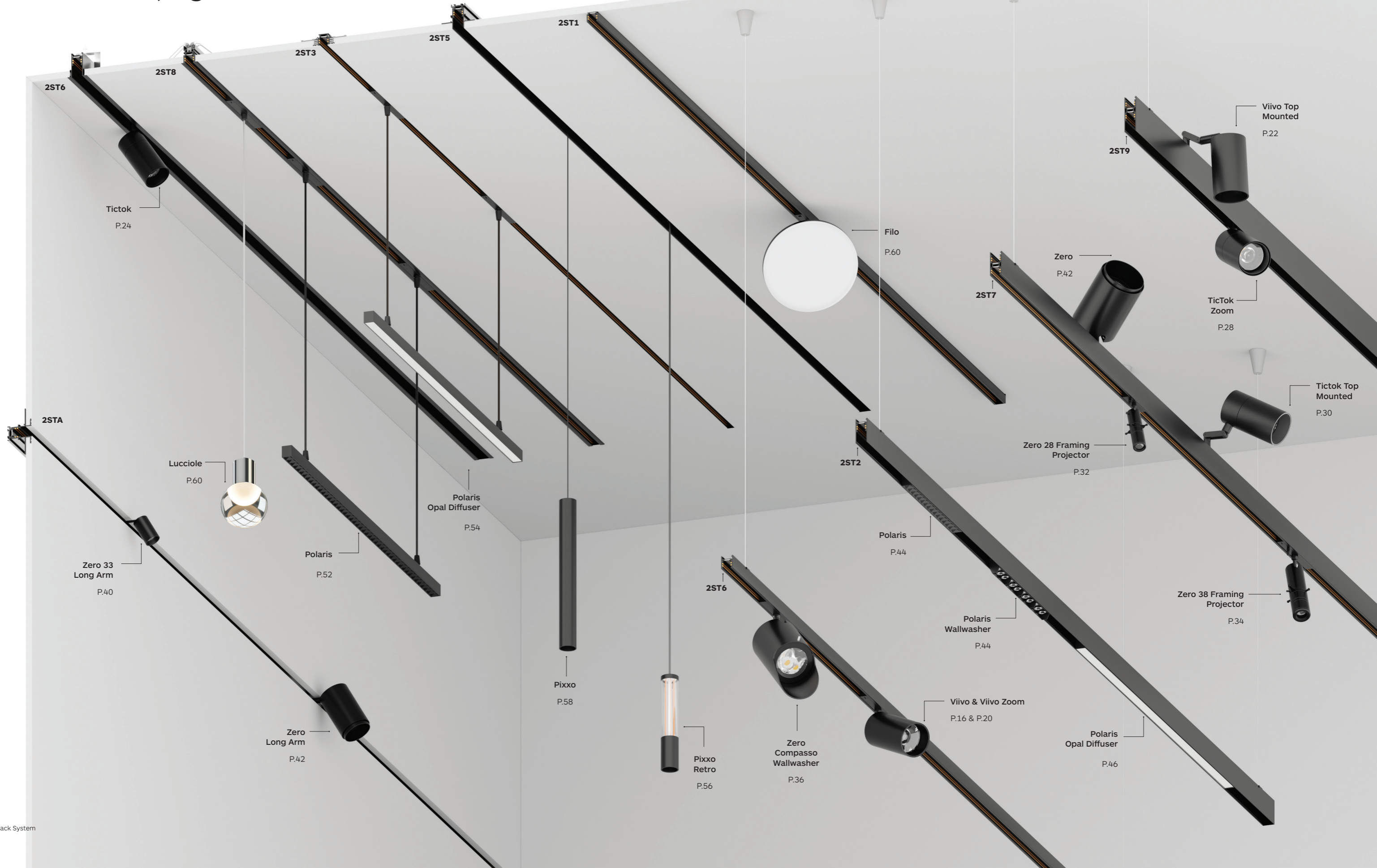

Tictok  
P.24

Lucciole  
P.60

Zero 33  
Long Arm  
P.40

Zero  
Long Arm  
P.42

Polaris  
P.52

Polaris  
Opal Diffuser  
P.54

Pixxo  
P.58

Pixxo  
Retro  
P.56

Zero  
Compasso  
Wallwasher  
P.36

Viivo & Viivo Zoom  
P.16 & P.20

Polaris  
Wallwasher  
P.44

Polaris  
P.44

Zero 28 Framing  
Projector  
P.32

Zero 38 Framing  
Projector  
P.34

Tictok Top  
Mounted  
P.30

TicTok  
Zoom  
P.28

Zero  
P.42

Filo  
P.60

Viivo Top  
Mounted  
P.22

formalighting

**EVO 48V**

**Track System**

formalighting

# Viivo

25 | 35 | 45 | 58 | 75  
EVO 48V Track

- 10 - Black
- 65 - Embossed matt black
- 11 - White
- 54 - Embossed matt white

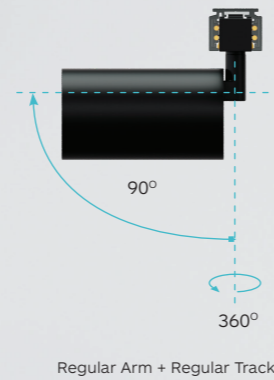

Viivo enables users to create unique lighting schemes and configurations.

Energy-saving, track mounted on a EVO 48V track system, with integrated driver in the track adaptor - the focus is on eco-friendly design and modularity.

Tool-free interchangeable LED modules facilitate design flexibility and ease of on-site maintenance. Available in five different adjustable light head sizes Ø25, Ø35, Ø45, Ø58 and Ø75mm, with versatile aiming angle tiltable 0°-90° and rotatable 360°.

Available in embossed matt black/white finishing; make it the perfect solution for retail, hospitality, and high-end residences.

Viivo is available with Casambi and DALI control options. DALI dimmable fixtures can also be controlled by Casambi DALI Broadcast device, please see pages 66-67 for details.

For complete code ordering information, please see page 85.



### LED Sources:

High Efficacy:  
CRI: 90 & 93 | CCT: 2700K, 3000K, 3500K, 4000K.

High Rendering:  
CRI: 97 & 98 | CCT: 2700K, 3000K, 3500K, 4000K.

### Accessories:

- Wide & Dense Texture Honeycomb Louvre
  - Elliptical Beam Diffuser
  - Coloured Glasses Diffuser
  - Opal Lens
  - Spread Lens
  - Cross blade Louvre
  - Barn doors
  - Wallwasher Cone 45°
- Please see page 62 for details.

# Viivo

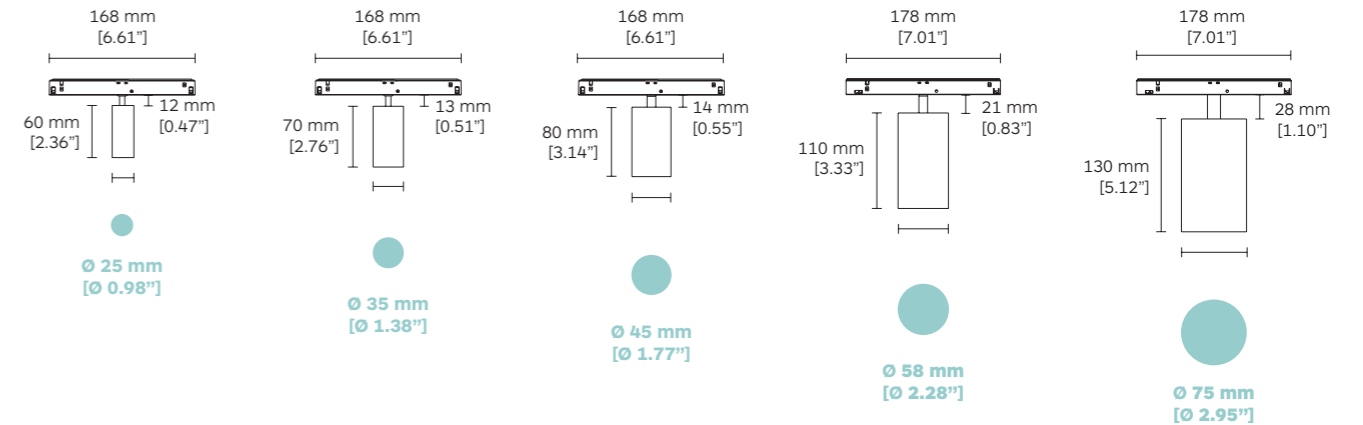

|  | Product Code | LED Module Code | LED Power   | Nominal Lumen  | Beam Angle (BA°)       |
|--|--------------|-----------------|-------------|----------------|------------------------|
| <b>CRI&gt;90</b><br><b>3000K</b><br>High Efficacy  | Viivo 25     | <b>96A8</b>     | <b>E017</b> | 3.4W<br>370 lm | <b>15° / 20° / 32°</b> |
|  | Viivo 35     | <b>96A9</b>     | <b>E013</b> | 5W<br>691 lm   | <b>20° / 24° / 38°</b> |
|  |              |                 | <b>E063</b> | 2.1W<br>195 lm | <b>05°</b>             |
|  | Viivo 45     | <b>96B0</b>     | <b>JC02</b> | 9W<br>1101 lm  | <b>18° / 28° / 38°</b> |
|  | Viivo 58     | <b>96B1</b>     | <b>JC01</b> | 14W<br>1730 lm | <b>24° / 34°</b>       |
| <b>CRI&gt;93</b><br><b>3000K</b><br>High Efficacy  | Viivo 75     | <b>96C7</b>     | <b>E029</b> | 18W<br>2305 lm | <b>12° / 26° / 36°</b> |
|  |              |                 |             | 15W<br>1632 lm | <b>12° / 18°</b>       |
| <b>CRI&gt;97</b><br><b>3000K</b><br>High Rendering | Viivo 35     | <b>96A9</b>     | <b>E013</b> | 5W<br>620 lm   | <b>20° / 24° / 38°</b> |
|  | Viivo 45     | <b>96B0</b>     | <b>E051</b> | 8W<br>738 lm   | <b>08°</b>             |
|  | Viivo 58     | <b>96B1</b>     | <b>JC01</b> | 14W<br>1590 lm | <b>24° / 34°</b>       |
| <b>CRI&gt;98</b><br><b>3000K</b><br>High Rendering | Viivo 75     | <b>96C7</b>     | <b>E006</b> | 18W<br>1765 lm | <b>14° / 26° / 37°</b> |
|  |              |                 |             | 15W<br>1418 lm | <b>12° / 18°</b>       |

- Dimming Options
- D0** No Dim
  - DA** Dali Dim
  - DC** CASAMBI
  - D1** 0-10V Dim

- CCT Options
- 27** 2700K
  - 30** 3000K
  - 35** 3500K
  - 40** 4000K

# Viivo Long Arm

25 | 35 | 45 | 58 | 75  
EVO 48V Track



- 10 - Black
- 65 - Embossed matt black
- 11 - White
- 54 - Embossed matt white

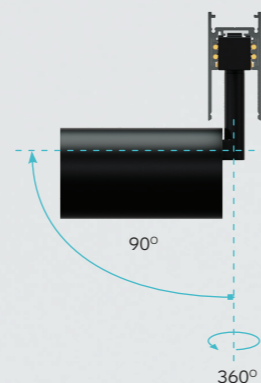

Long Arm + Deep Track

Viivo Long Arm is designed for deep recessed and pendant EVO 48V track applications. Energy-saving, track mounted on a EVO 48V track system, with integrated driver in the track adaptor - the focus is on eco-friendly design and modularity.

Tool-free interchangeable LED modules facilitate design flexibility and ease of on-site maintenance. Available in five different adjustable light head sizes Ø25, Ø35, Ø45, Ø58 and Ø75mm, with versatile aiming angle tiltable 0°-90° and rotatable 360°.

Available in embossed matt black/white finishing; make it the perfect solution for retail, hospitality, and high-end residences.

Viivo Long Arm is available with Casambi and DALI control options. DALI dimmable fixtures can also be controlled by Casambi DALI Broadcast device, please see pages 66-67 for details.

For complete code ordering information, please see page 85.



**LED Sources:**

High Efficacy:  
CRI: 90 & 93 | CCT: 2700K, 3000K, 3500K, 4000K.

High Rendering:  
CRI: 97 & 98 | CCT: 2700K, 3000K, 3500K, 4000K.

**Accessories:**

- Wide & Dense Texture Honeycomb Louvre
  - Elliptical Beam Diffuser
  - Coloured Glasses Filters
  - Opal Lens
  - Spread Lens
  - Cross blade Louvre
  - Barn doors
  - Wallwasher Cone 45°
- Please see page 62 for details.

# Viivo Long Arm

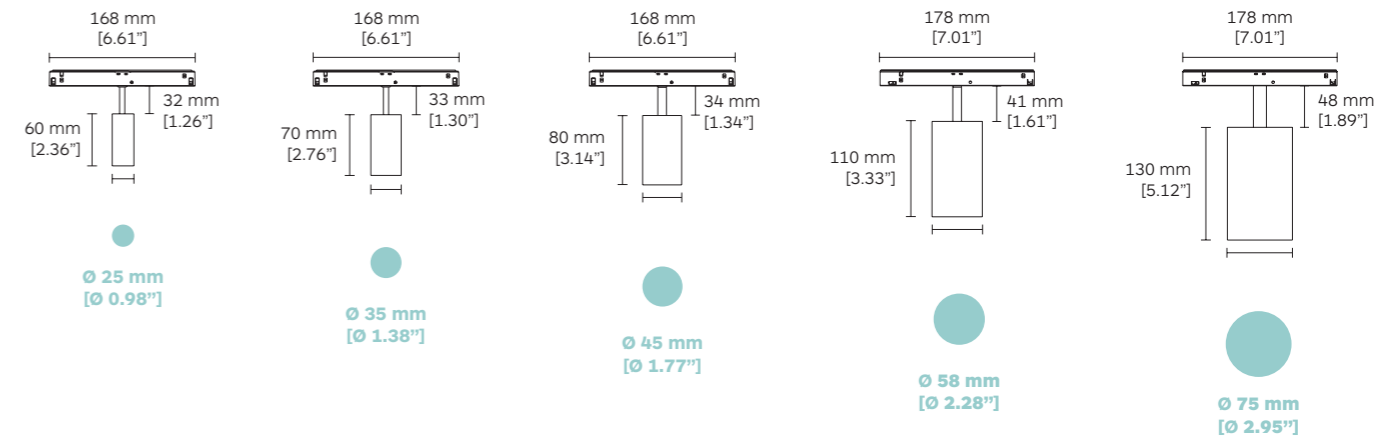

|   | Product Code | LED Module Code | LED Power      | Nominal Lumen    | Beam Angle (BA°)       |
|---|--------------|-----------------|----------------|------------------|------------------------|
| <b>CRI&gt;90</b><br>3000K<br>High Efficacy  | Viivo 25     | <b>96C8</b>     | <b>E017</b>    | 3.4W<br>370 lm   | <b>15° / 20° / 32°</b> |
|   | Viivo 35     | <b>96C9</b>     | <b>E063</b>    | 2.1W<br>195 lm   | <b>05°</b>             |
|   |              |                 | <b>E013</b>    | 5W<br>691 lm     | <b>24° / 38°</b>       |
|   | Viivo 45     | <b>96D0</b>     | <b>JC02</b>    | 9W<br>1101 lm    | <b>18° / 26° / 38°</b> |
|   |              |                 |                | 10W<br>969 lm    | <b>12°</b>             |
|   | Viivo 58     | <b>96D1</b>     | <b>JC01</b>    | 14W<br>1730 lm   | <b>24° / 34°</b>       |
|   |              |                 |                | 15W<br>1632 lm   | <b>12° / 18°</b>       |
| <b>CRI&gt;93</b><br>3000K<br>High Efficacy  | Viivo 75     | <b>96D2</b>     | <b>E029</b>    | 18W<br>2305 lm   | <b>12° / 26° / 36°</b> |
|   |              |                 |                |                  |                        |
| <b>CRI&gt;97</b><br>3000K<br>High Rendering | Viivo 35     | <b>96C9</b>     | <b>E013</b>    | 5W<br>620 lm     | <b>20° / 24° / 38°</b> |
|   | Viivo 45     | <b>96D0</b>     | <b>JC02</b>    | 9W<br>975 lm     | <b>18° / 26° / 38°</b> |
|   |              |                 |                | 10W<br>922 lm    | <b>12°</b>             |
|   | Viivo 58     | <b>96D1</b>     | <b>JC01</b>    | 14W<br>1590 lm   | <b>24° / 34°</b>       |
|   |              |                 | 15W<br>1418 lm | <b>12° / 18°</b> |                        |
| <b>CRI&gt;98</b><br>3000K<br>High Rendering | Viivo 75     | <b>96D2</b>     | <b>E006</b>    | 18W<br>1765 lm   | <b>14° / 26° / 37°</b> |

- Dimming Options
- D0** No Dim
  - DA** Dali Dim
  - DC** CASAMBI
  - D1** 0-10V Dim

- CCT Options
- 27** 2700K
  - 30** 3000K
  - 35** 3500K
  - 40** 4000K

# Viivo Zoom

45 | 58 | 75  
EVO 48V Track

Viivo Zoom is designed with a focus on eco-friendly engineering and modularity. Its tool-free, interchangeable LED module enhances design flexibility and simplifies on-site maintenance.

Available in Ø45, Ø58, and Ø75 mm diameters, Viivo Zoom features a versatile aiming angle that tilts from 0° to 90° and rotates 360°. The beam angle can be manually adjusted via a ring rotation mechanism. The luminaire is offered in standard surface-mounted, deep recessed, and pendant EVO track configurations, providing a ready-to-use solution that delivers greater flexibility, energy efficiency, and sustainability. Viivo Zoom is available with Casambi or DALI control options.

For complete code ordering information, please see page 85.



**LED Sources:**

High Efficacy:  
CRI: 90 | CCT: 2700K, 3000K, 3500K, 4000K.

High Rendering:  
CRI: 97 | CCT: 2700K, 3000K, 3500K, 4000K.

**Accessories:**

For more information about EVO 48V track accessories see pages 68-71.

- 10 - Black
- 65 - Embossed matt black
- 11 - White
- 54 - Embossed Matt White

## Viivo Zoom

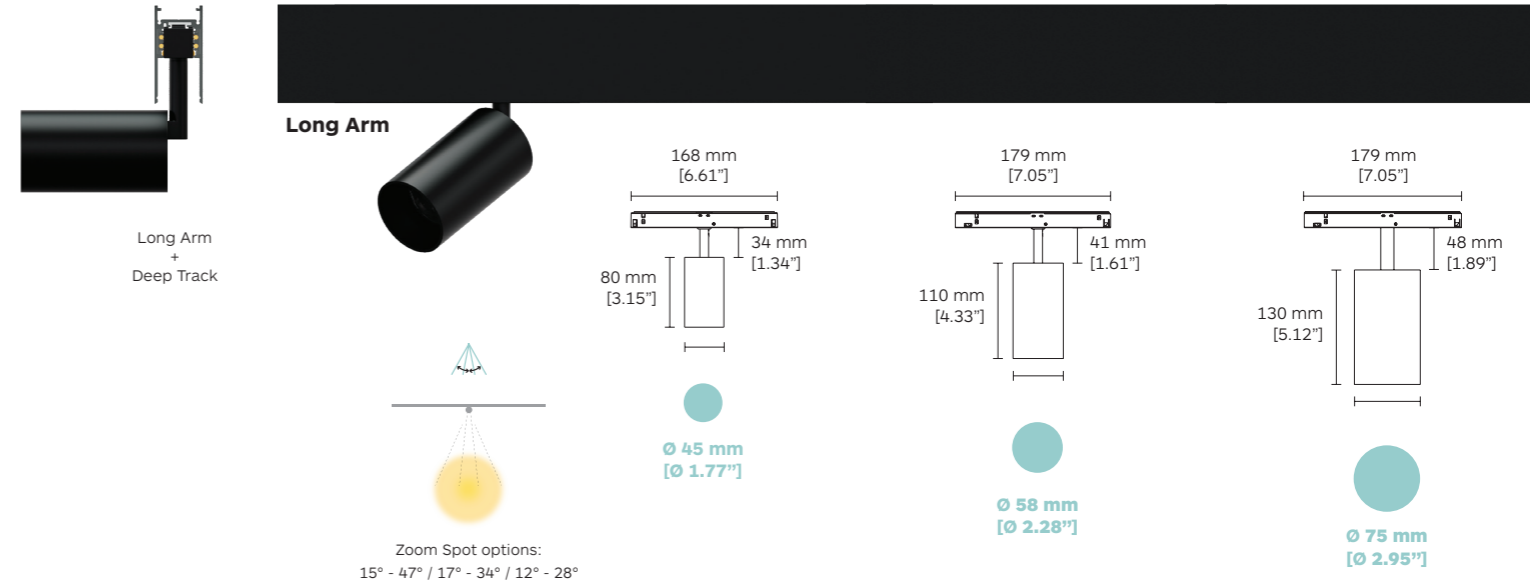
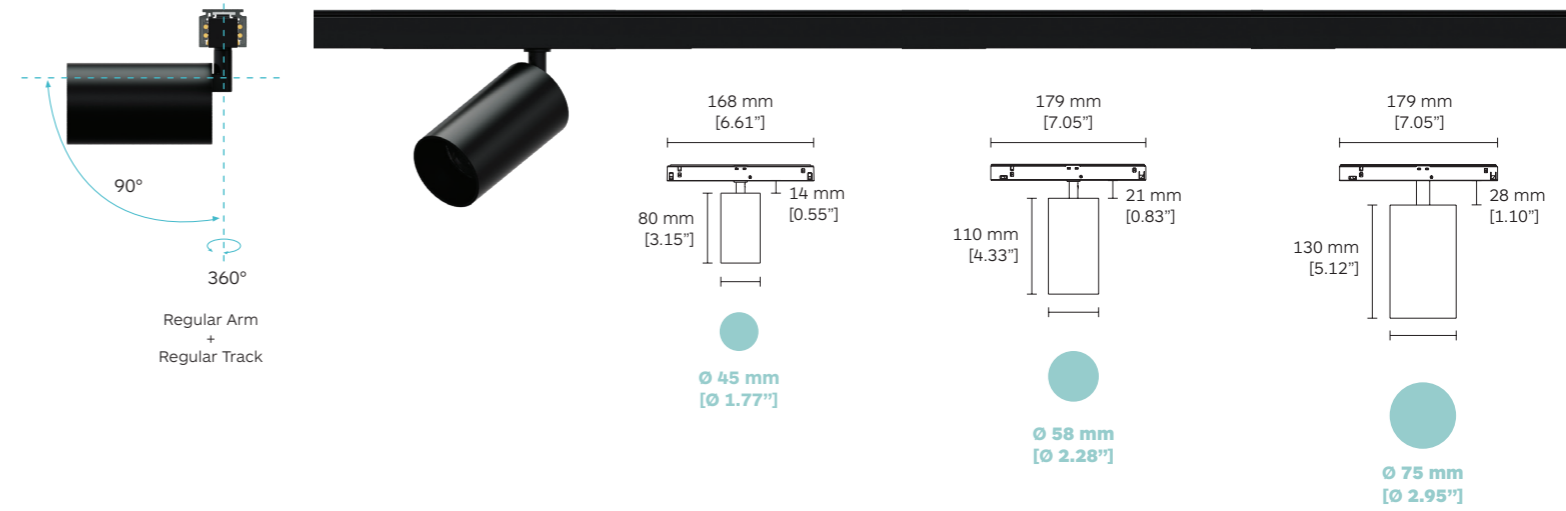

|   | Product Code           | LED Module Code | LED Power | Nominal Lumen | Beam Angle (BA°) | Dimming Options | CCT Options |
|---|------------------------|-----------------|-----------|---------------|------------------|-----------------|-------------|
| <b>CRI&gt;90<br/>3000K<br/>High Efficacy</b>  | Viivo Zoom 45          | 96D3            | E077      | 5.5W          | 634 lm           | BS (15°-47°)    | 27 2700K    |
|   | Viivo Zoom 45 Long Arm | 96D4            |           |               |                  |                 | 30 3000K    |
|   | Viivo Zoom 58          | 96D5            | E030      | 15W           | 1632 lm          | BS (17°-34°)    | 35 3500K    |
|   | Viivo Zoom 58 Long Arm | 96D6            |           |               |                  |                 | 40 4000K    |
| <b>CRI&gt;97<br/>3000K<br/>High Rendering</b> | Viivo Zoom 75          | 96D7            | E035      | 19W           | 1937 lm          | BS (12°-28°)    |             |
|   | Viivo Zoom 75 Long Arm | 96D8            |           |               |                  |                 |             |
|   | Viivo Zoom 45          | 96D3            | E077      | 5.5W          | 606 lm           | BS (15°-47°)    |             |
|   | Viivo Zoom 45 Long Arm | 96D4            |           |               |                  |                 |             |
|   | Viivo Zoom 58          | 96D5            | E030      | 15W           | 1418 lm          | BS (17°-34°)    |             |
|   | Viivo Zoom 58 Long Arm | 96D6            |           |               |                  |                 |             |
|   | Viivo Zoom 75          | 96D7            | E035      | 19W           | 1651 lm          | BS (12°-28°)    |             |
|   | Viivo Zoom 75 Long Arm | 96D8            |           |               |                  |                 |             |

# Viivo Top Mounted

45 | 58 | 75  
EVO 48V Track

Viivo Top Mount is designed for H-shaped pendant profiles and is available in 48V EVO track applications.

Viivo Series focuses on eco-friendly design and modularity. TicTok's tool-free, and interchangeable LED module facilitate design flexibility and ease of on-site maintenance. The tool-free interchangeable LED module is available in Ø45, Ø58 and Ø75mm head sizes, the extended arm of the top mount design provides extra vertical tiltable and rotation angles: an eco-friendly onsite maintainable solution.

For complete code ordering information, please see page 85.

- 10 - Black
- 65 - Embossed matt black
- 11 - White
- 54 - Embossed matt white

### LED Sources:

High Efficacy:  
CRI: 93 | CCT: 2700K, 3000K, 3500K, 4000K

High Rendering:  
CRI: 98 | CCT: 2700K, 3000K, 3500K, 4000K

### Accessories:

- Wide & Dense Texture Honeycomb Louvre
  - Elliptical Beam Diffuser
  - Coloured Glasses Diffuser
  - Opal Lens
  - Spread Lens
  - Cross blade Louvre
  - Barn doors
  - Wallwasher Cone 45°
- Please see page 62 for details.

# Viivo Top Mounted



### Angle Adjustment:

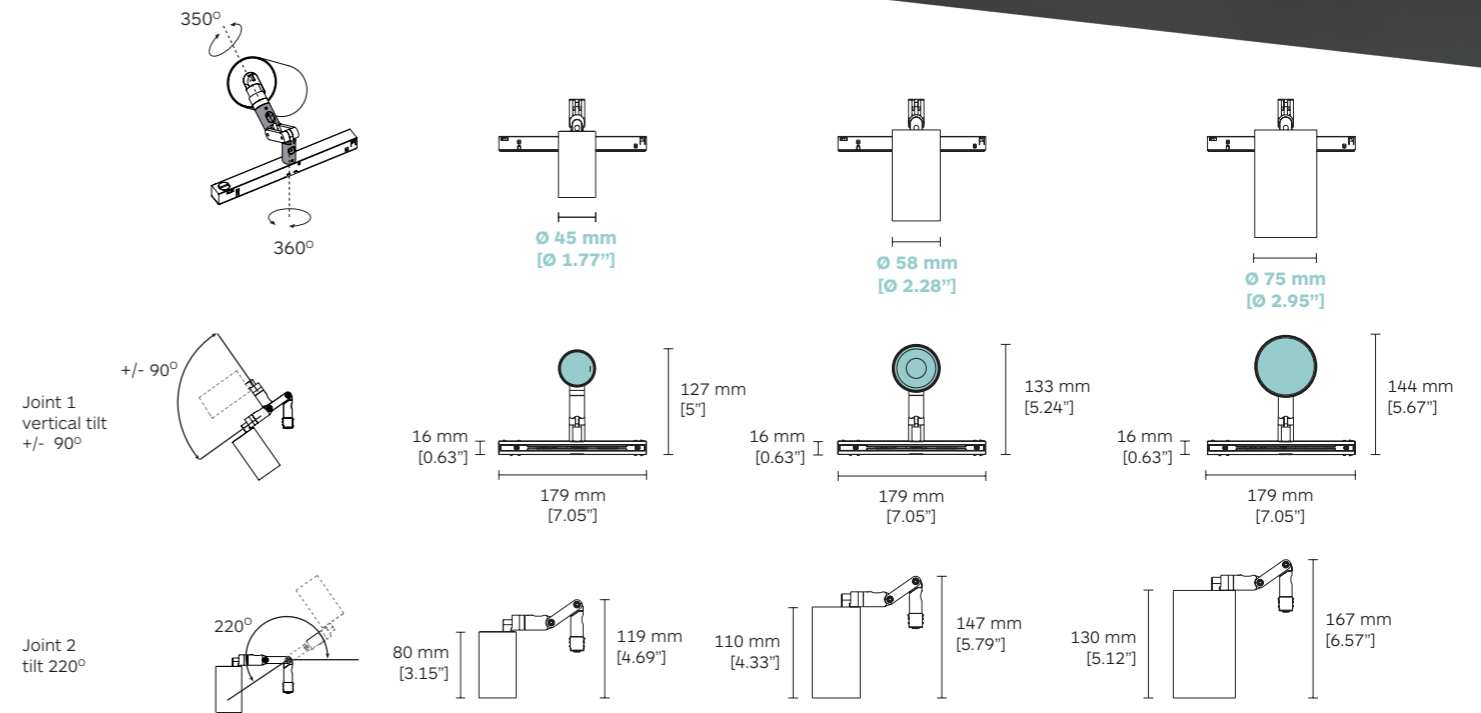

|   | Product Code | LED Module Code | LED Power   | Nominal Lumen | Beam Angle (BA°) | Dimming Options        | CCT Options     |
|---|--------------|-----------------|-------------|---------------|------------------|------------------------|-----------------|
| <b>CRI&gt;90<br/>3000K High Efficacy</b>  | Viivo 45     | <b>96J1</b>     | <b>JC02</b> | 9W            | 1101 lm          | <b>18° / 26° / 36°</b> | <b>27</b> 2700K |
|   |              |                 |             | 10W           | 969 lm           | <b>12°</b>             | <b>30</b> 3000K |
|   | Viivo 58     | <b>96J2</b>     | <b>JC01</b> | 14W           | 1730 lm          | <b>12° / 18°</b>       | <b>35</b> 3500K |
|   |              |                 | 15W         | 1632 lm       | <b>24° / 34°</b> | <b>40</b> 4000K        |                 |
| <b>CRI&gt;90<br/>3000K High Efficacy</b>  | Viivo 75     | <b>96J3</b>     | <b>E029</b> | 18W           | 2305 lm          | <b>13° / 26° / 36°</b> |                 |
| <b>CRI&gt;97<br/>3000K High Rendering</b> | Viivo 45     | <b>96J1</b>     | <b>JC02</b> | 9W            | 975 lm           | <b>18° / 26° / 36°</b> |                 |
|   |              |                 |             | 10W           | 922 lm           | <b>12°</b>             |                 |
|   | Viivo 58     | <b>96J2</b>     | <b>E027</b> | 14W           | 1590 lm          | <b>12° / 18°</b>       |                 |
|   |              |                 | 15W         | 1418 lm       | <b>24° / 34°</b> |                        |                 |
| <b>CRI&gt;98<br/>3000K High Rendering</b> | Viivo 75     | <b>96J3</b>     | <b>E006</b> | 18W           | 1765 lm          | <b>14° / 26° / 37°</b> |                 |

# TicTok

25 | 35 | 45 | 58 | 75  
EVO 48V Track



- 10 - Black
- 65 - Embossed matt black
- 11 - White
- 54 - Embossed matt white

TicTok enables users to create unique lighting schemes and configurations.

Energy-saving, track mounted on a EVO 48V track system, with integrated driver in the track adaptor - the focus is on eco-friendly design and modularity.

TicTok's tool-free interchangeable LED module facilitates design flexibility and ease of on-site maintenance. Available in five different adjustable light head sizes Ø25, Ø35, Ø45, Ø58 and Ø75mm, with versatile aiming angle tiltable 0°-70° and rotatable 360°.

Designed to be the perfect solution for accent lighting in sustainable lighting design schemes for retail, hospitality and high-end residences. A ready-to-use solution for greater flexibility, energy efficiency, and sustainability.

TicTok is available with Casambi or DALI control options. DALI dimmable fixtures can also be controlled by Casambi DALI Broadcast device, please see pages 66-67 for details.

For complete code ordering information, please see page 85.

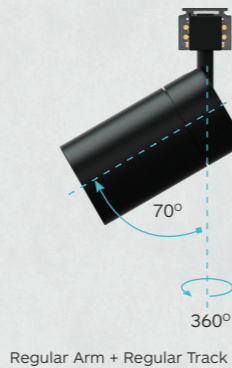

**LED Sources:**

High Efficacy:  
CRI: 90 & 93 | CCT: 2700K, 3000K, 3500K, 4000K.

High Rendering:  
CRI: 97 & 98 | CCT: 2700K, 3000K, 3500K, 4000K.

**Accessories:**

- Wide & Dense Texture Honeycomb Louvre
  - Elliptical Beam Diffuser
  - Coloured Glasses Filters
  - Opal Lens
  - Spread Lens
  - Cross blade Louvre
  - Barn doors
  - Wallwasher Cone 45°
- Please see page 62 for details.

# TicTok

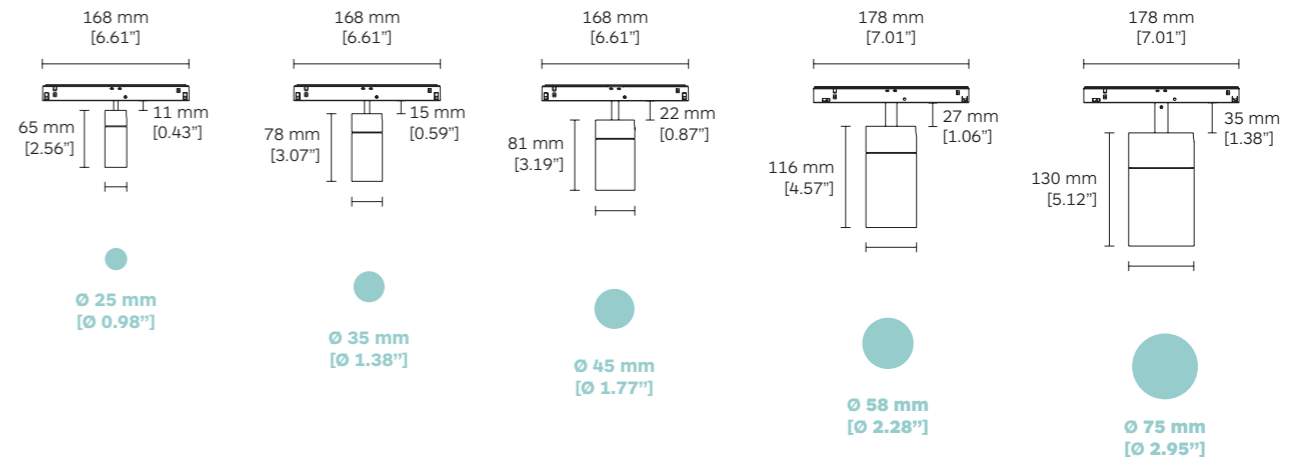

|  | Product Code | LED Module Code | LED Power      | Nominal Lumen    | Beam Angle (BA°)       | Dimming Options     |
|--|--------------|-----------------|----------------|------------------|------------------------|---------------------|
| <b>CRI&gt;90</b><br><b>3000K</b><br>High Efficacy  | TicTok 25    | <b>96B2</b>     | <b>E017</b>    | 3.4W<br>370 lm   | <b>15° / 20° / 32°</b> | <b>D0</b> No Dim    |
|  | TicTok 35    | <b>96B3</b>     | <b>E013</b>    | 2.1W<br>195 lm   | <b>05°</b>             | <b>DA</b> Dali Dim  |
|  |              |                 |                | 5W<br>691 lm     | <b>20° / 24° / 38°</b> | <b>DC</b> CASAMBI   |
|  | TicTok 45    | <b>9662</b>     | <b>JC02</b>    | 9W<br>975 lm     | <b>18° / 26° / 38°</b> | <b>D1</b> 0-10V Dim |
|  |              |                 |                | 10W<br>969 lm    | <b>12°</b>             |                     |
|  | TicTok 58    | <b>9664</b>     | <b>JC01</b>    | 14W<br>1730 lm   | <b>24° / 34°</b>       |                     |
|  |              |                 | 15W<br>1632 lm | <b>12° / 18°</b> |                        |                     |
| <b>CRI&gt;93</b><br><b>3000K</b><br>High Efficacy  | TicTok 75    | <b>9666</b>     | <b>E029</b>    | 18W<br>2305 lm   | <b>12° / 26° / 36°</b> |                     |
|  |              |                 |                |                  |                        |                     |
| <b>CRI&gt;97</b><br><b>3000K</b><br>High Rendering | TicTok 35    | <b>96B3</b>     | <b>E013</b>    | 5W<br>620 lm     | <b>08°</b>             |                     |
|  | TicTok 45    | <b>9662</b>     | <b>JC02</b>    | 9W<br>975 lm     | <b>18° / 26° / 38°</b> |                     |
|  |              |                 |                | 10W<br>969 lm    | <b>12°</b>             |                     |
|  | TicTok 58    | <b>9664</b>     | <b>JC01</b>    | 14W<br>1590 lm   | <b>24° / 34°</b>       |                     |
|  |              |                 | 15W<br>1418 lm | <b>12° / 18°</b> |                        |                     |
| <b>CRI&gt;98</b><br><b>3000K</b><br>High Rendering | TicTok 75    | <b>9666</b>     | <b>E006</b>    | 18W<br>1765 lm   | <b>14° / 26° / 37°</b> |                     |

- CCT Options
- 27** 2700K
  - 30** 3000K
  - 35** 3500K
  - 40** 4000K

# TicTok Long Arm

25 | 35 | 45 | 58 | 75  
EVO 48V Track



- 10 - Black
- 65 - Embossed matt black
- 11 - White
- 54 - Embossed matt white

TicTok Long Arm is designed for deep recessed and pendant EVO 48V track applications.

TicTok focus on eco-friendly design and modularity.

TicTok's tool-free, and interchangeable LED module facilitates design flexibility and ease of on-site maintenance. Available in five different adjustable light head sizes Ø25, Ø35, Ø45, Ø58 and Ø75mm, with versatile aiming angle tiltable 0°-70° and rotatable 360°.

Perfect solution for accent lighting in sustainable lighting design schemes for retail, hospitality and high-end residences. A ready-to-use solution for greater flexibility, energy efficiency, and sustainability.

TicTok is available with Casambi or DALI control options. DALI dimmable fixtures can also be controlled by Casambi DALI Broadcast device, please see pages 66-67 for details.

For complete code ordering information, please see page 85.

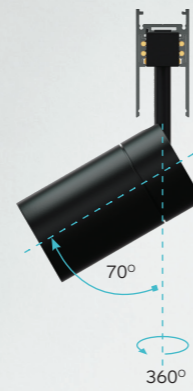

Long Arm + Deep Track



**LED Sources:**

High Efficacy:  
CRI: 90 & 93 | CCT: 2700K, 3000K, 3500K, 4000K.

High Rendering:  
CRI: 95 & 98 | CCT: 2700K, 3000K, 3500K, 4000K.

**Accessories:**

- Wide & Dense Texture Honeycomb Louvre
- Elliptical Beam Diffuser
- Coloured Glasses Filters
- Opal Lens
- Spread Lens
- Cross blade Louvre
- Barn doors
- Wallwasher Cone 45°
- Please see page 62 for details.

# TicTok Long Arm

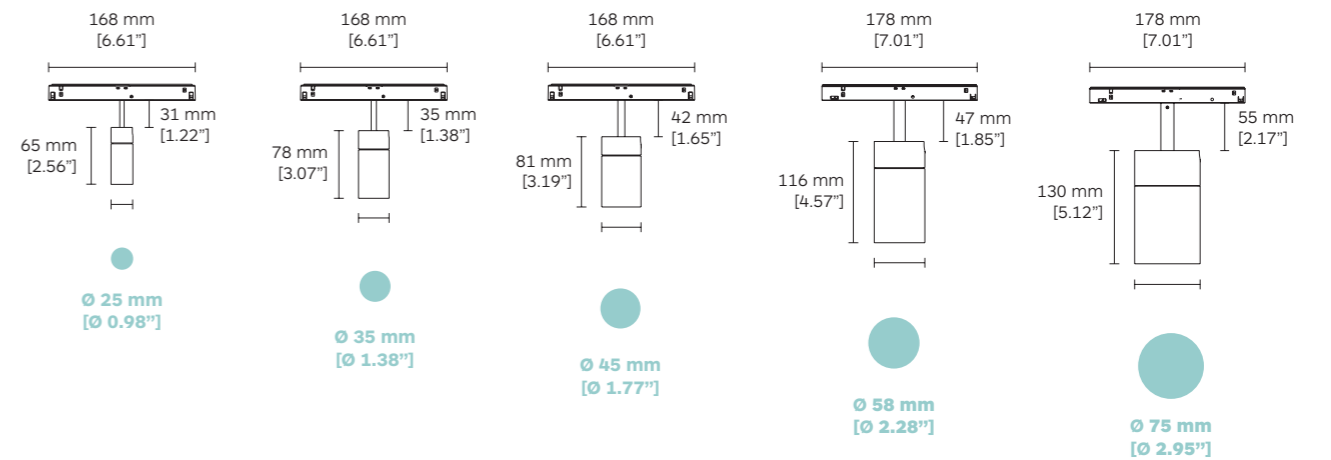

|   | Product Code | LED Module Code | LED Power      | Nominal Lumen    | Beam Angle (BA°)   | Dimming Options  |
|---|--------------|-----------------|----------------|------------------|--|--|
| <b>CRI &gt; 90</b><br>3000K<br>High Efficacy  | TicTok 25    | <b>96C3</b>     | <b>E017</b>    | 3.4W<br>370 lm   | <b>15° / 20° / 32°</b>   | <b>D0</b> No Dim<br><b>DA</b> Dali Dim<br><b>DC</b> CASAMBI<br><b>D1</b> 0-10V Dim |
|   | TicTok 35    | <b>96C4</b>     | <b>E013</b>    | 2.1W<br>195 lm   | <b>05°</b>   |  |
|   |              |                 |                | 5W<br>691 lm     | <b>20° / 24° / 38°</b>   |  |
|   | TicTok 45    | <b>9663</b>     | <b>JC02</b>    | 9W<br>1101 lm    | <b>18° / 26° / 38°</b>   |  |
|   | TicTok 58    | <b>9665</b>     | <b>JC01</b>    | 10W<br>969 lm    | <b>12°</b>   |  |
|   |              |                 | 14W<br>1730 lm | <b>24° / 34°</b> | <b>CCT Options</b><br><b>27</b> 2700K<br><b>30</b> 3000K<br><b>35</b> 3500K<br><b>40</b> 4000K |  |
|   |              |                 | 15W<br>1632 lm | <b>12° / 18°</b> |  |  |
| <b>CRI &gt; 93</b><br>3000K<br>High Efficacy  | TicTok 75    | <b>9667</b>     | <b>E029</b>    | 18W<br>2305 lm   |  | <b>12° / 26° / 36°</b>   |
|   |              |                 |                |                  |  |  |
| <b>CRI &gt; 97</b><br>3000K<br>High Rendering | TicTok 35    | <b>96C4</b>     | <b>E013</b>    | 5W<br>620 lm     |  | <b>20° / 24° / 38°</b>   |
|   | TicTok 45    | <b>9663</b>     | <b>JC02</b>    | 9W<br>975 lm     | <b>18° / 26° / 38°</b>   |  |
|   |              |                 |                | 10W<br>922 lm    | <b>12°</b>   |  |
|   | TicTok 58    | <b>9665</b>     | <b>JC01</b>    | 14W<br>1590 lm   | <b>24° / 34°</b>   |  |
|   |              |                 | 15W<br>1418 lm | <b>12° / 18°</b> |  |  |
| <b>CRI &gt; 98</b><br>3000K<br>High Rendering | TicTok 75    | <b>9667</b>     | <b>E006</b>    | 18W<br>1765 lm   | <b>14° / 26° / 37°</b>   |  |

# TicTok Zoom

45 | 58 | 75  
EVO 48V Track



- 10 - Black
- 65 - Embossed matt black
- 11 - White
- 54 - Embossed matt white

TicTok Zoom focus on eco-friendly design and modularity. TicTok Zoom tool-free interchangeable LED module facilitates design flexibility and ease of on-site maintenance.

Available in Ø45, Ø58mm & Ø75mm, with versatile aiming angle tiltable 0°-70° and rotatable 360°. The beam angle is manually adjustable through ring rotation, from 10° to 38°. It is available in standard surface, deep recessed, and pendant EVO 48V track applications.

A ready-to-use solution for greater flexibility, energy efficiency, and sustainability.

TicTok is available with Casambi or DALI control options. DALI dimmable fixtures can also be controlled by Casambi DALI Broadcast device, please see pages 66-67 for details.

For complete code ordering information, please see page 85.



**LED Sources:**

High Efficacy:  
CRI: 90 | CCT: 2700K, 3000K, 3500K, 4000K.

High Rendering:  
CRI: 97 | CCT: 2700K, 3000K, 3500K, 4000K.

**Accessories:**

For more information about EVO 48V track accessories see pages 66-73.

## TicTok Zoom

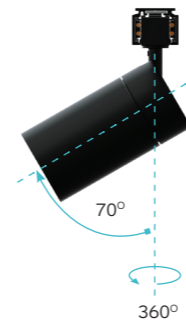

Regular Arm + Regular Track



Long Arm + Deep Track

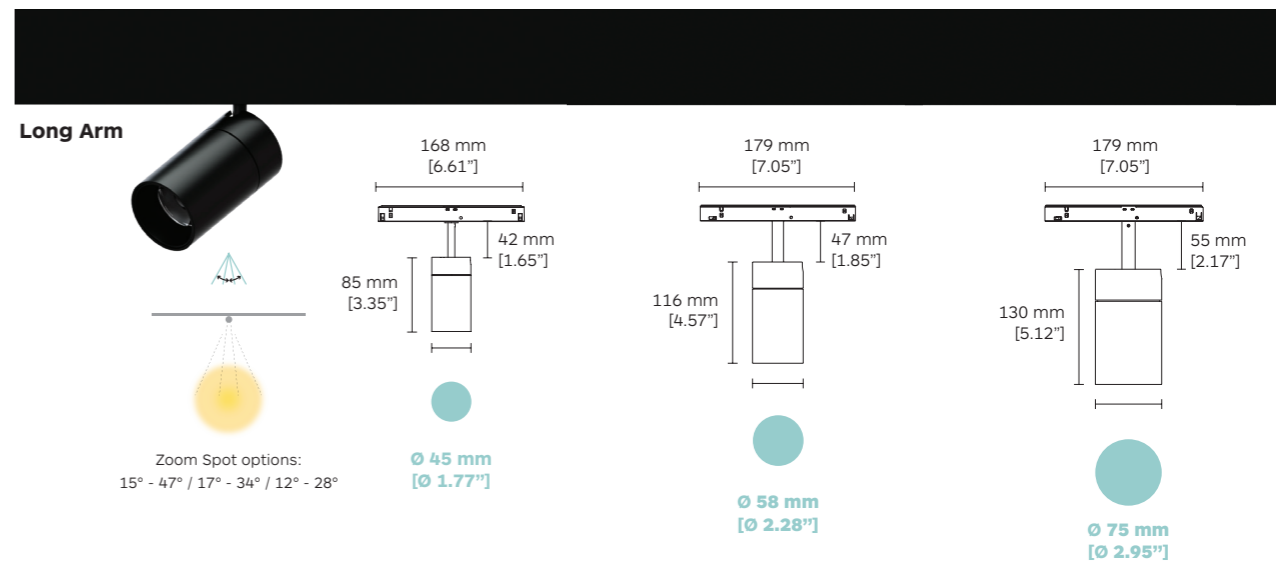
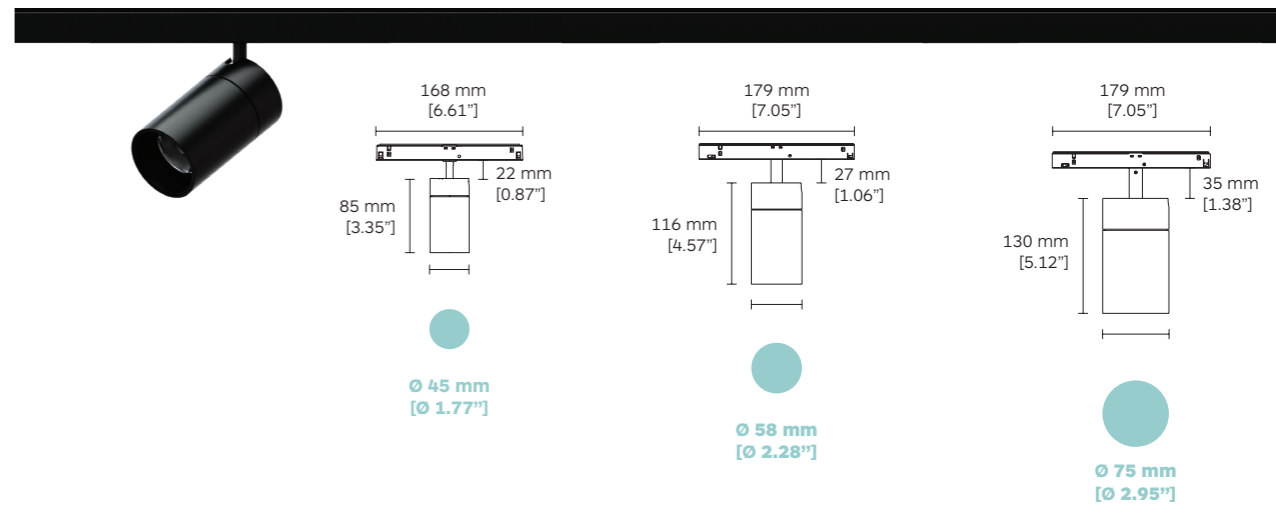

Zoom Spot options:  
15° - 47° / 17° - 34° / 12° - 28°

|   | Product Code            | LED Module Code | LED Power   | Nominal Lumen | Beam Angle (BA°) | Dimming Options     | CCT Options     |
|---|-------------------------|-----------------|-------------|---------------|------------------|---------------------|-----------------|
| <b>CRI&gt;90<br/>3000K<br/>High Efficacy</b>  | TicTok Zoom 45          | <b>96A6</b>     | <b>E077</b> | 5.5W          | 634 lm           | <b>BS</b> (15°-47°) | <b>27</b> 2700K |
|   | TicTok Zoom 45 Long Arm | <b>96C5</b>     |             |               |                  |                     | <b>30</b> 3000K |
|   | TicTok Zoom 58          | <b>96A7</b>     | <b>E030</b> | 15W           | 1632 lm          | <b>BS</b> (17°-34°) | <b>35</b> 3500K |
|   | TicTok Zoom 58 Long Arm | <b>96C6</b>     |             |               |                  |                     | <b>40</b> 4000K |
| <b>CRI&gt;97<br/>3000K<br/>High Rendering</b> | TicTok Zoom 75          | <b>9668</b>     | <b>E035</b> | 19W           | 1937 lm          | <b>BS</b> (12°-28°) |                 |
|   | TicTok Zoom 75 Long Arm | <b>9669</b>     |             |               |                  |                     |                 |
|   | TicTok Zoom 45          | <b>96A6</b>     | <b>E077</b> | 5.5W          | 606 lm           | <b>BS</b> (12°-37°) |                 |
|   | TicTok Zoom 45 Long Arm | <b>96C5</b>     |             |               |                  |                     |                 |
|   | TicTok Zoom 58          | <b>96A7</b>     | <b>E030</b> | 15W           | 1418 lm          | <b>BS</b> (17°-27°) |                 |
|   | TicTok Zoom 58 Long Arm | <b>96C6</b>     |             |               |                  |                     |                 |
|   | TicTok Zoom 75          | <b>9668</b>     | <b>E035</b> | 19W           | 1651 lm          | <b>BS</b> (12°-28°) |                 |
|   | TicTok Zoom 75 Long Arm | <b>9669</b>     |             |               |                  |                     |                 |

# TicTok Top Mounted

45 | 58 | 75  
EVO 48V Track

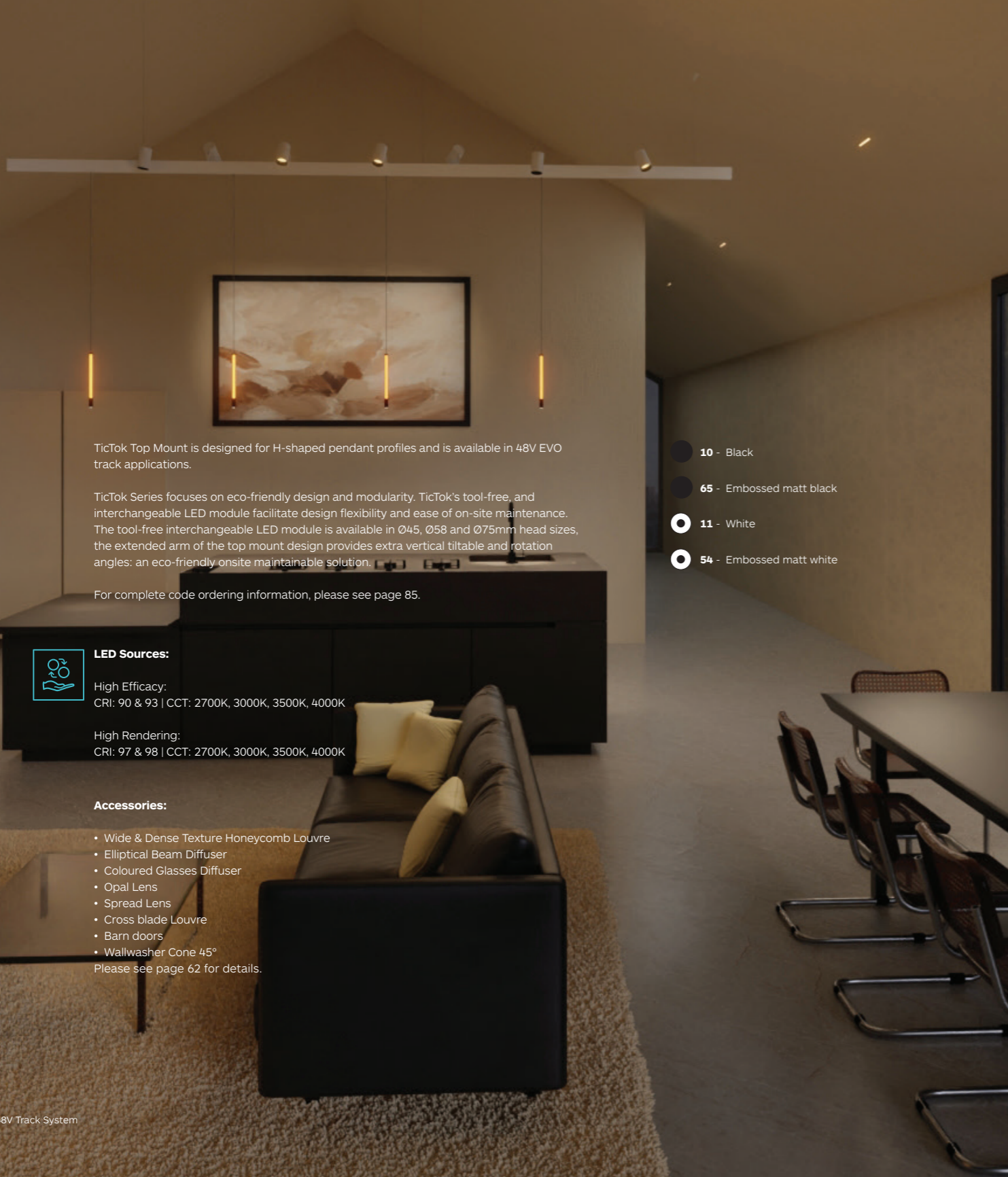

TicTok Top Mount is designed for H-shaped pendant profiles and is available in 48V EVO track applications.

TicTok Series focuses on eco-friendly design and modularity. TicTok's tool-free, and interchangeable LED module facilitate design flexibility and ease of on-site maintenance. The tool-free interchangeable LED module is available in Ø45, Ø58 and Ø75mm head sizes, the extended arm of the top mount design provides extra vertical tiltable and rotation angles: an eco-friendly onsite maintainable solution.

For complete code ordering information, please see page 85.

### LED Sources:

High Efficacy:  
CRI: 90 & 93 | CCT: 2700K, 3000K, 3500K, 4000K

High Rendering:  
CRI: 97 & 98 | CCT: 2700K, 3000K, 3500K, 4000K

### Accessories:

- Wide & Dense Texture Honeycomb Louvre
- Elliptical Beam Diffuser
- Coloured Glasses Diffuser
- Opal Lens
- Spread Lens
- Cross blade Louvre
- Barn doors
- Wallwasher Cone 45°

Please see page 62 for details.

- 10 - Black
- 65 - Embossed matt black
- 11 - White
- 54 - Embossed matt white

## TicTok Top Mounted



### Angle Adjustment:

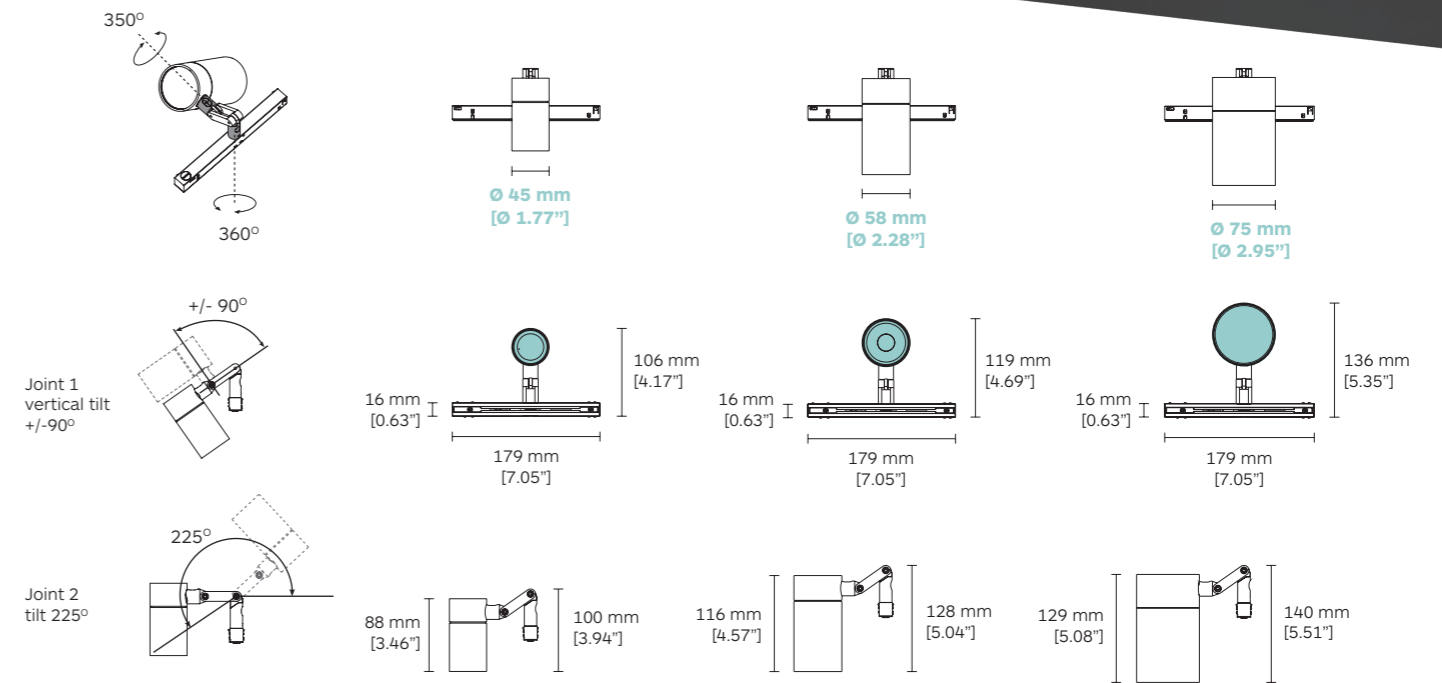

|                                   | Product Code | LED Module Code | LED Power | Nominal Lumen | Beam Angle (BA°) | Dimming Options | CCT Options  |
|-----------------------------------|--------------|-----------------|-----------|---------------|------------------|-----------------|--|
| CRI>90<br>3000K<br>High Efficacy  | TicTok 45    | 96H8            | JC02      | 9W            | 1101 lm          | 18° / 26° / 36° | D0 No Dim<br>D1 0-10V Dim<br>DA Dali Dim<br>DC CASAMBI |
|                                   |              |                 |           | 10W           | 969 lm           | 12°             |  |
|                                   | TicTok 58    | 96H9            | JC01      | 14W           | 1730 lm          | 12° / 18°       |  |
|                                   |              |                 |           | 15W           | 1632 lm          | 24° / 34°       |  |
| CRI>93<br>3000K<br>High Efficacy  | TicTok 75    | 96J0            | E029      | 18W           | 2305 lm          | 13° / 26° / 36° |  |
| CRI>97<br>3000K<br>High Rendering | TicTok 45    | 96H8            | JC02      | 9W            | 975 lm           | 18° / 26° / 36° | 27 2700K<br>30 3000K<br>35 3500K<br>40 4000K           |
|                                   |              |                 |           | 10W           | 922 lm           | 12°             |  |
|                                   | TicTok 58    | 96H9            | E027      | 14W           | 1590 lm          | 12° / 18°       |  |
|                                   |              |                 |           | 15W           | 1418 lm          | 24° / 34°       |  |
| CRI>98<br>3000K<br>High Rendering | TicTok 75    | 96J0            | E006      | 18W           | 1765 lm          | 14° / 26° / 37° |  |

# Zero 28 Framing Projector

EVO 48V Track

- 10 - Black
- 11 - White

**LED Sources:**

High Rendering:  
CRI: 97 | CCT: 2700K, 3000K, 3500K, 4000K

**Accessories:**

- Gobo Film, see page 63 for details.
- Contact us for custom-made logo projection lens.



Zero 28 framing projector is an advanced, multi-functional EVO 48V track-mounted projector, tiltable vertically 0°-90° and rotatable horizontally 360°. With built-in bidirectional zooming lens with sharpness adjustability, and lens rotation. Available in regular and long arm version for deep recessed and pendant EVO 48V track.

Fully adjustable shutters to reframe the beam to the desired size and shape (circle, square/rectangle, or irregular four-sided shapes). Compatible with Gobo insertion for logo. High-precision optics for sharp outlines and a high degree of lighting uniformity.

For complete code ordering information, please see page 85.

# Zero 28 Framing Projector

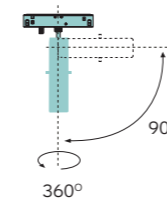
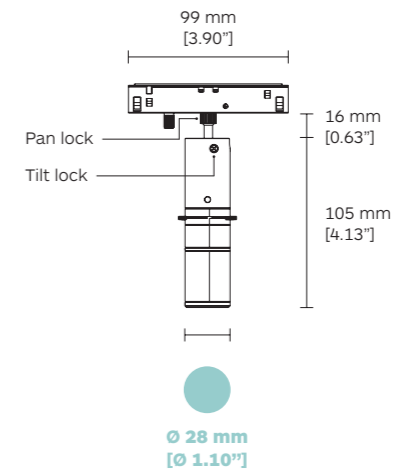
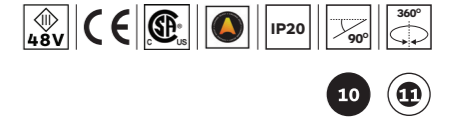

**CRI > 97**  
**3000K**  
High Rendering

Zero 28 Framing Projector

| Product Code | LED Source Code | LED Power | Nominal Lumen | Beam Angle (BA°)     | Dimming Options           | CCT Options     |
|--------------|-----------------|-----------|---------------|----------------------|---------------------------|-----------------|
| <b>96H7</b>  | <b>BC53</b>     | 4.8W      | 470 lm        | <b>BS (11°- 32°)</b> | <b>DO</b> No Dim          | <b>27</b> 2700K |
|              |                 |           |               |                      | <b>DC</b> CASAMBI         | <b>30</b> 3000K |
|              |                 |           |               |                      | <b>DA</b> Dali Dim        | <b>35</b> 3500K |
|              |                 |           |               |                      | <b>DN</b> On Board Dimmer | <b>40</b> 4000K |

# Zero 38 Framing Projector

EVO 48V Track

- 10 - Black
- 65 - Embossed matt black
- 11 - White
- 54 - Embossed matt white

Zero 38 framing projector is an advanced, multi-functional EVO 48V track-mounted projector, tiltable vertically 0°-90° and rotatable horizontally 350°. With built-in bidirectional zooming lens with sharpness adjustability, and lens rotation. Available in regular and long arm version for deep recessed and pendant EVO 48V track.

Fully adjustable shutters to reframe the beam to the desired size and shape (circle, square/rectangle, or irregular four-sided shapes). Compatible with Gobo insertion for logo. High-precision optics for sharp outlines and a high degree of lighting uniformity.

Zero 38 framing projector is available with Casambi or DALI control options. DALI dimmable fixtures can also be controlled by Casambi DALI Broadcast device, please see pages 66-67 for details.

For complete code ordering information, please see page 85.

**LED Sources:**

High Rendering:  
CRI: 97 | CCT: 2700K, 3000K, 3500K, 4000K.

**Accessories:**

- Gobo Film, see page 61 for details  
Contact us for custom-made logo projection lens.

## Zero 38 Framing Projector

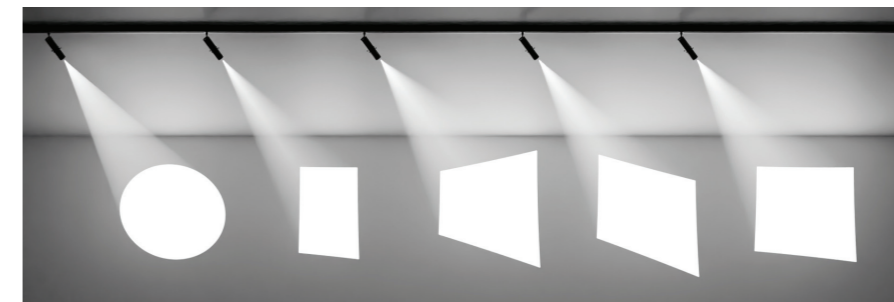
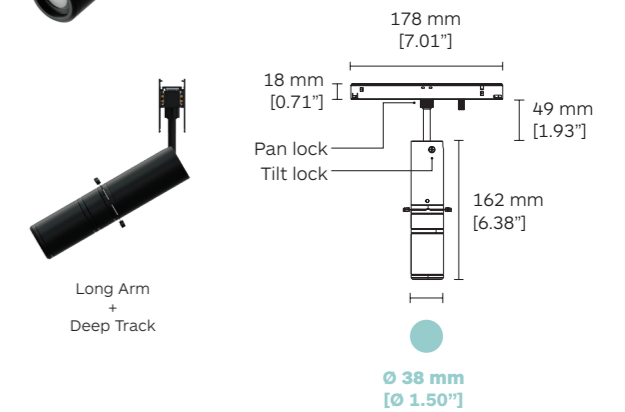
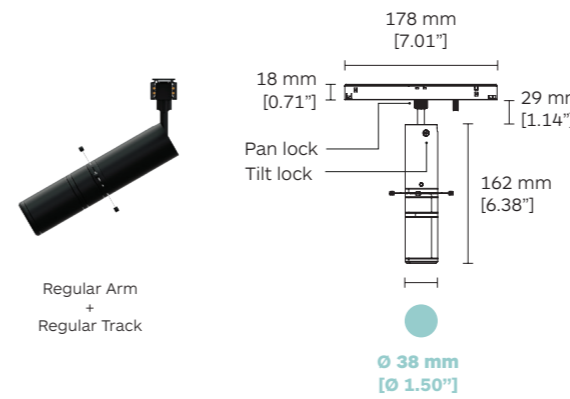

Recommended distance from fixture to wall between 0.5metres to 10metres.



Gobo Film logo projector lens. Accessory Art. 2G24

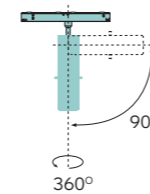

|   | Product Code                       | LED Source Code | LED Power   | Nominal Lumen | Beam Angle (BA°) | Dimming Options           | CCT Options     |
|---|------------------------------------|-----------------|-------------|---------------|------------------|---------------------------|-----------------|
| <b>CRI&gt;97</b><br><b>3000K</b><br><b>High Rendering</b> | Zero Framing Projector 38          | <b>96A4</b>     | <b>BC42</b> | 9.7W          | 922 lm           | <b>BS</b> (14°-35°)       | <b>27</b> 2700K |
|   | Zero Framing Projector 38 Long Arm | <b>96A5</b>     |             |               |                  |                           | <b>30</b> 3000K |
|   |                                    |                 |             |               |                  | <b>DC</b> CASAMBI         | <b>35</b> 3500K |
|   |                                    |                 |             |               |                  | <b>DA</b> Dali Dim        | <b>40</b> 4000K |
|   |                                    |                 |             |               |                  | <b>DN</b> On Board Dimmer |                 |

BS: Beam Shaping.

# Zero Compasso Wallwasher

42 | 66 | 100  
EVO 48V Track

- 10 - Black
- 65 - Embossed matt black
- 11 - White
- 54 - Embossed matt white

EVO 48V track mounted Zero Compasso wallwasher, available in three sizes (Ø42, Ø66 and Ø100mm) versatile aiming angle tiltable vertically 0°-90° and rotatable horizontally 360°. Available in regular and long arm version for deep recessed and pendant EVO 48V track.

Perfect for museums and galleries applications. Wallwashing with high uniformity can be used to illuminate artwork and sculptures. Vertical uniformity creates a wide and distinguished spatial impression by brightening the entire height of the wall.

DALI dimmable fixtures can also be controlled by Casambi DALI Broadcast device, please see pages 66-67 for details.

For complete code ordering information, please see page 85.

**LED Sources:**

High Efficacy:  
CRI: 90 | CCT: 2700K, 3000K, 3500K, 4000K.

High Rendering:  
CRI: 97 | CCT: 2700K, 3000K, 3500K, 4000K.

**Accessories:**

For more information about EVO 48V track accessories see pages 66-73.

# Zero Compasso Wallwasher

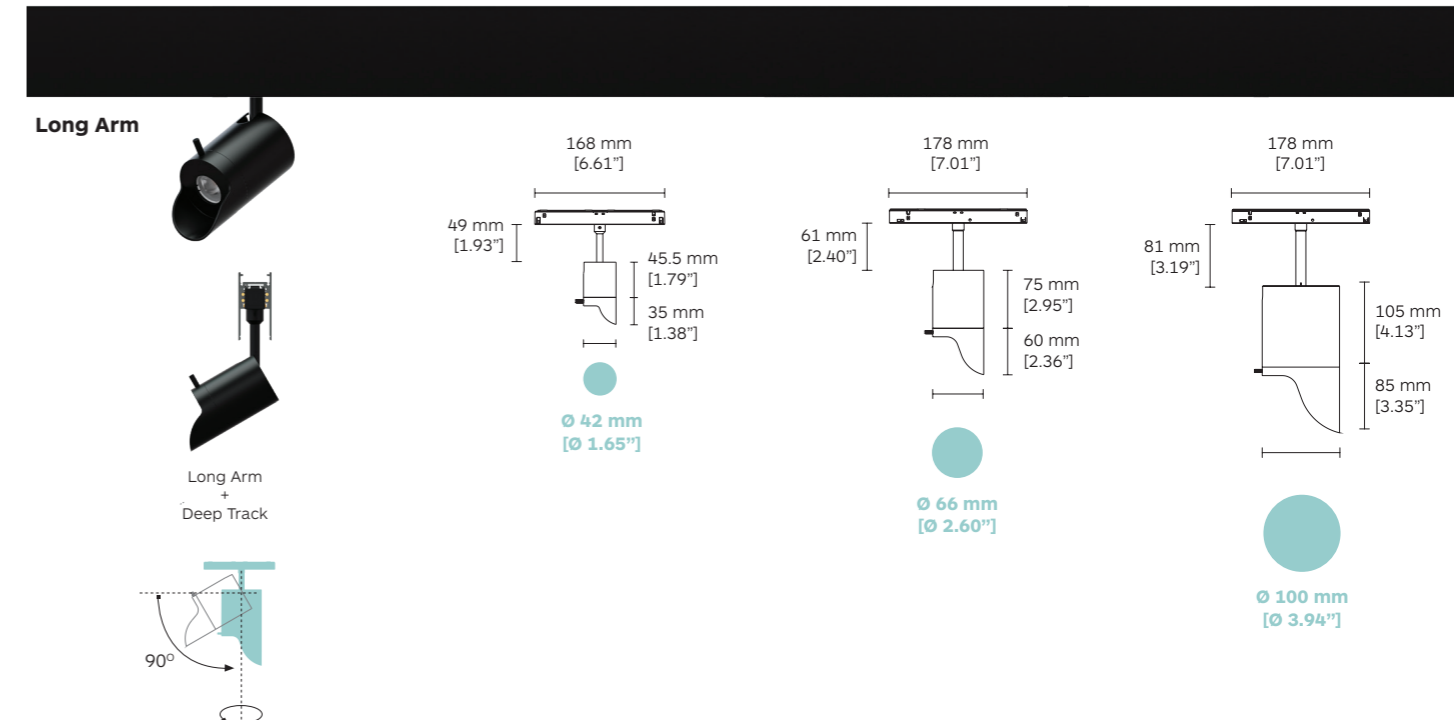
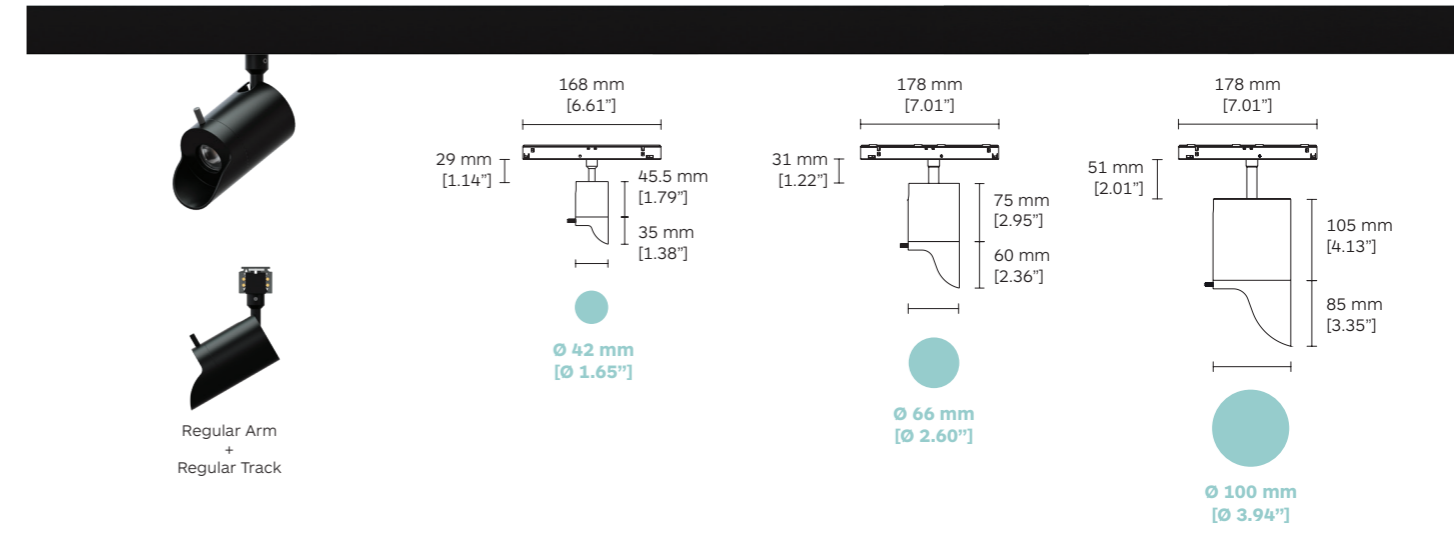

|   | Product Code                          | LED Module Code | LED Power   | Nominal Lumen | Beam Angle (BA°) | Dimming Options    | CCT Options     |
|---|---------------------------------------|-----------------|-------------|---------------|------------------|--------------------|-----------------|
| <b>CRI&gt;90<br/>3000K<br/>High Efficacy</b>  | Zero Compasso 42 Wallwasher           | <b>9673</b>     | <b>BR21</b> | 4W            | 439 lm           | <b>WW</b> No Dim   | <b>27</b> 2700K |
|   | Zero Compasso 42 Wallwasher Long Arm  | <b>96E5</b>     |             |               |                  | <b>DA</b> Dali Dim | <b>30</b> 3000K |
| <b>CRI&gt;97<br/>3000K<br/>High Rendering</b> | Zero Compasso 66 Wallwasher           | <b>9671</b>     | <b>BC22</b> | 12W           | 1550 lm          | <b>DC</b> CASAMBI  | <b>35</b> 3500K |
|   | Zero Compasso 66 Wallwasher Long Arm  | <b>96E6</b>     |             |               |                  |                    | <b>40</b> 4000K |
|   | Zero Compasso 100 Wallwasher          | <b>9672</b>     | <b>BC33</b> | 14W           | 1789 lm          |                    |                 |
|   | Zero Compasso 100 Wallwasher Long Arm | <b>96E7</b>     |             |               |                  |                    |                 |

WW = Wallwasher. Ordering code; **WW**.



# Zero Compasso Wallwasher

Lighting Effects



Zero Compasso 66 Wallwasher



Zero Compasso 100 Wallwasher

## Example of a wallwasher table

Illuminances 1x (Wall)

|                            | Zero Compasso 66 Wallwasher |      |      |      | Zero Compasso 100 Wallwasher |      |      |      |
|----------------------------|-----------------------------|------|------|------|------------------------------|------|------|------|
| Angle of tilt ( $\alpha$ ) | 10°                         |      |      |      | 0°                           |      |      |      |
| Wall Height (m)            | 3                           |      |      |      | 4                            |      |      |      |
| Wall Width (m)             | 7                           |      |      |      | 7                            |      |      |      |
| Offset from Wall y         | 1.00                        | 1.25 | 1.50 | 1.50 | 1.00                         | 1.25 | 1.50 | 1.50 |
| Luminaire spacing (m) x    | 0.83                        | 1.00 | 1.25 | 1.50 | 1.00                         | 1.25 | 1.50 | 1.50 |
| Illuminance (lx) Average   | 141                         | 117  | 105  | 78   | 126                          | 105  | 93   | 70   |
| Illuminance (lx) Max       | 242                         | 201  | 180  | 134  | 223                          | 186  | 165  | 124  |

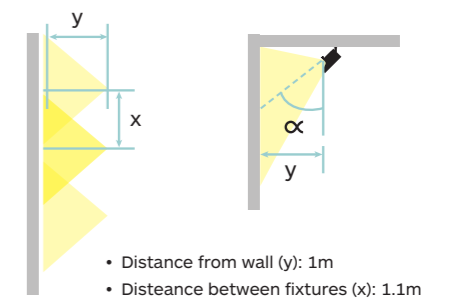

### Luminaire spacing

The luminaire spacing (x) for some wallwashers can vary by up to 1.5 times the wall offset (y). Corresponding details are provided in the wallwasher table in catalog datasheets. Computerized beam calculations are recommended to check potential intersections with side walls.

### Wallwasher angle of tilt

The lens wallwasher requires tilting. The product data sheet specifies the optimal tilt angle ( $\alpha$ ) for uniform light distribution on the wall.

# Zero 33

## EVO 48V Track

Zero 33 miniature design track spot projector with high lumen intensity values. Available in regular and long arm versions for deep recessed and pendant EVO 48V track.

Featuring an onboard beam angle adjustment (8-80°) to resolve the most complex focal points and dimming control (1-100%) to adjust the light's intensity while remaining invisible from short distances. Fully adjustable vertically tiltable 0°-90° and rotatable horizontally 330°.

Optical accessories are easy to install with a unique magnet system. DALI dimmable fixtures can also be controlled by Casambi DALI Broadcast device, please see pages 66-67 for details.

For complete code ordering information, please see page 85.

### LED Sources:

High Efficacy:  
CRI: 90 | CCT: 2700K, 3000K, 3500K, 4000K.

### Accessories:

- Honeycomb Louvre
  - Diffuser
  - Barn doors
- Please see page 63 for details.

- 10 - Black
- 65 - Embossed matt black
- 11 - White
- 54 - Embossed matt white



# Zero 33

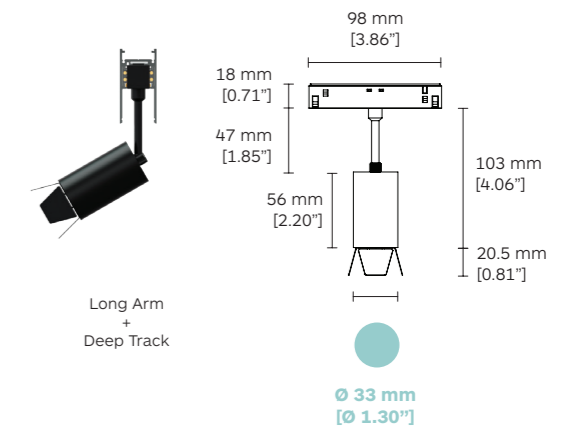
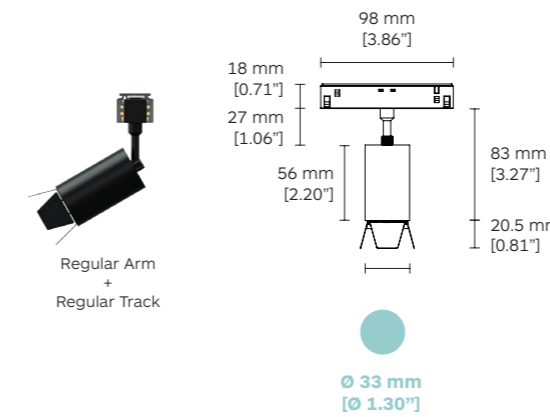
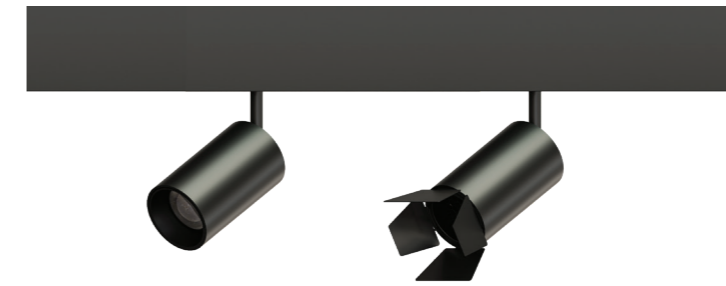

### Zoom Spotlights

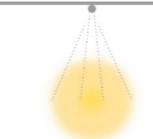

Zoom Spot 8° - 80°

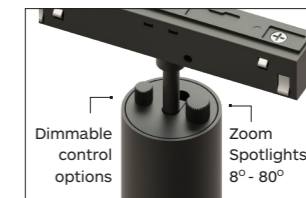
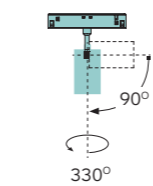

|                                  | Product Code     | LED Source Code | LED Power | Nominal Lumen | Beam Angle (BA°) | Dimming Options                                 | CCT Options                      |
|----------------------------------|------------------|-----------------|-----------|---------------|------------------|---|----------------------------------|
| CRI>90<br>3000K<br>High Efficacy | Zero 33          | 9648            | BR21      | 4.5W          | 448 lm           | BS (8-80°)                                      | 27 2700K                         |
|                                  | Zero 33 Long Arm | 9649            |           |               |                  | DA Dali Dim<br>DC CASAMBI<br>DN On-board Dimmer | 30 3000K<br>35 3500K<br>40 4000K |

# Zero

40 | 66 | 100  
EVO 48V Track



- 10 - Black
- 65 - Embossed matt black
- 11 - White
- 54 - Embossed matt white

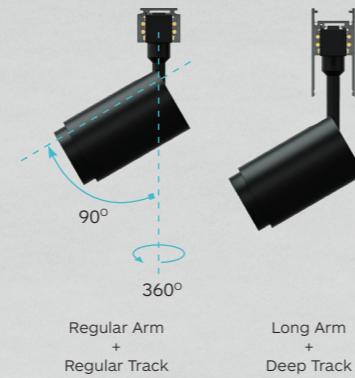

Zero compact aluminum housing designed for passive cooling. It is available in regular arm and long arm versions for deep recessed and pendant EVO 48V track.

Integrated dimmable driver in EVO 48V track adapter, available in Casambi or DALI control options. Available in three different sizes Ø40, Ø66, Ø100mm. Versatile aiming angle tiltable vertically 0°-90° and rotatable horizontally 360°.

DALI dimmable fixtures can also be controlled by Casambi DALI Broadcast device, please see pages 66-67 for details.

For complete code ordering information, please see page 85.

**LED Sources:**

High Efficacy:  
CRI: 90 | CCT: 2700K, 3000K, 3500K, 4000K, Tuneable White.

**Accessories:**

- Coloured Glasses Diffuser
  - Linear Spread
  - Honeycomb Louvre
  - Visor
  - Anti-Glare Tube
- Please see page 63 for details.

# Zero

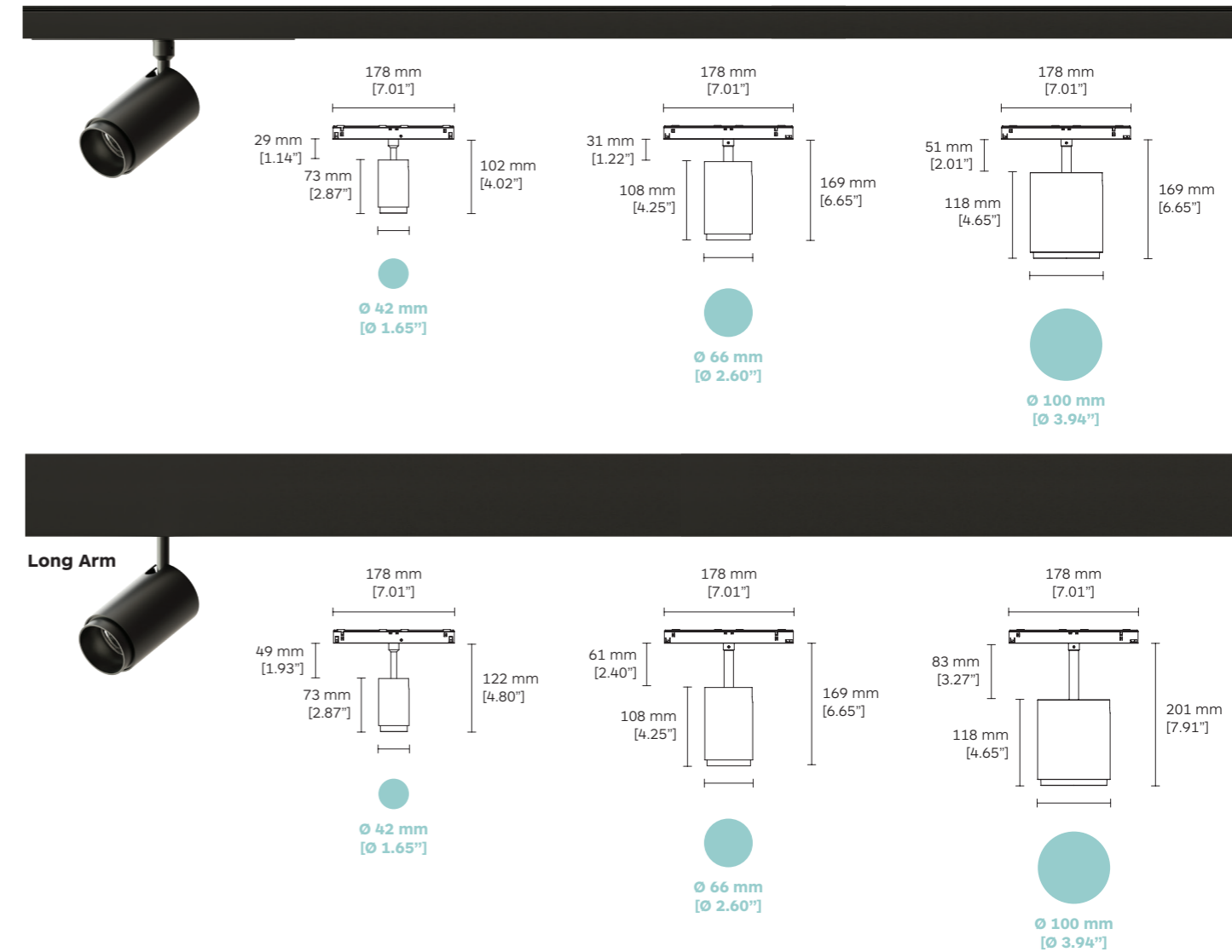

**CRI>90  
3000K  
High  
Efficacy**

|                   | Product Code | LED Source Code   | LED Power | Nominal Lumen | Beam Angle (BA°)       | Dimming Options    | CCT Options            |
|-------------------|--------------|-------------------|-----------|---------------|------------------------|--------------------|------------------------|
| Zero 40           | <b>9614</b>  | <b>BR21</b>       | 4W        | 439 lm        | <b>07°</b>             | <b>D0</b> No Dim   | <b>27</b> 2700K        |
| Zero 40 Long Arm  | <b>9631</b>  | <b>BC31</b>       | 6W        | 705 lm        | <b>16° / 26° / 36°</b> | <b>DA</b> Dali Dim | <b>30</b> 3000K        |
|                   |              | <b>BU11 (T2*)</b> | 7W        | 831 lm        | <b>26° / 32°</b>       | <b>DC</b> CASAMBI  | <b>35</b> 3500K        |
| Zero 66           | <b>9615</b>  | <b>BR21</b>       | 6W        | 574 lm        | <b>05°</b>             |                    | <b>40</b> 4000K        |
| Zero 66 Long Arm  | <b>9632</b>  | <b>BC22</b>       | 12W       | 1550 lm       | <b>16° / 25° / 36°</b> |                    | <b>*T2</b> 2700K-6500K |
|                   |              | <b>BC31</b>       | 11W       | 1160 lm       | <b>11° / 16° / 32°</b> |                    |                        |
|                   |              | <b>IU21 (T2*)</b> | 13W       | 1482 lm       | <b>24° / 30° / 43°</b> |                    |                        |
| Zero 100          | <b>9616</b>  | <b>BR21</b>       | 16W       | 1756 lm       | <b>07°</b>             |                    |                        |
| Zero 100 Long Arm | <b>9634</b>  | <b>BC33</b>       | 21W       | 2569 lm       | <b>15° / 24° / 38°</b> |                    |                        |
|                   |              | <b>BB31 (T2*)</b> | 21W       | 2411 lm       | <b>18° / 26° / 34°</b> |                    |                        |

T2 = Tuneable White

# Polaris

20 | 20 Wallwasher  
EVO 48V Track

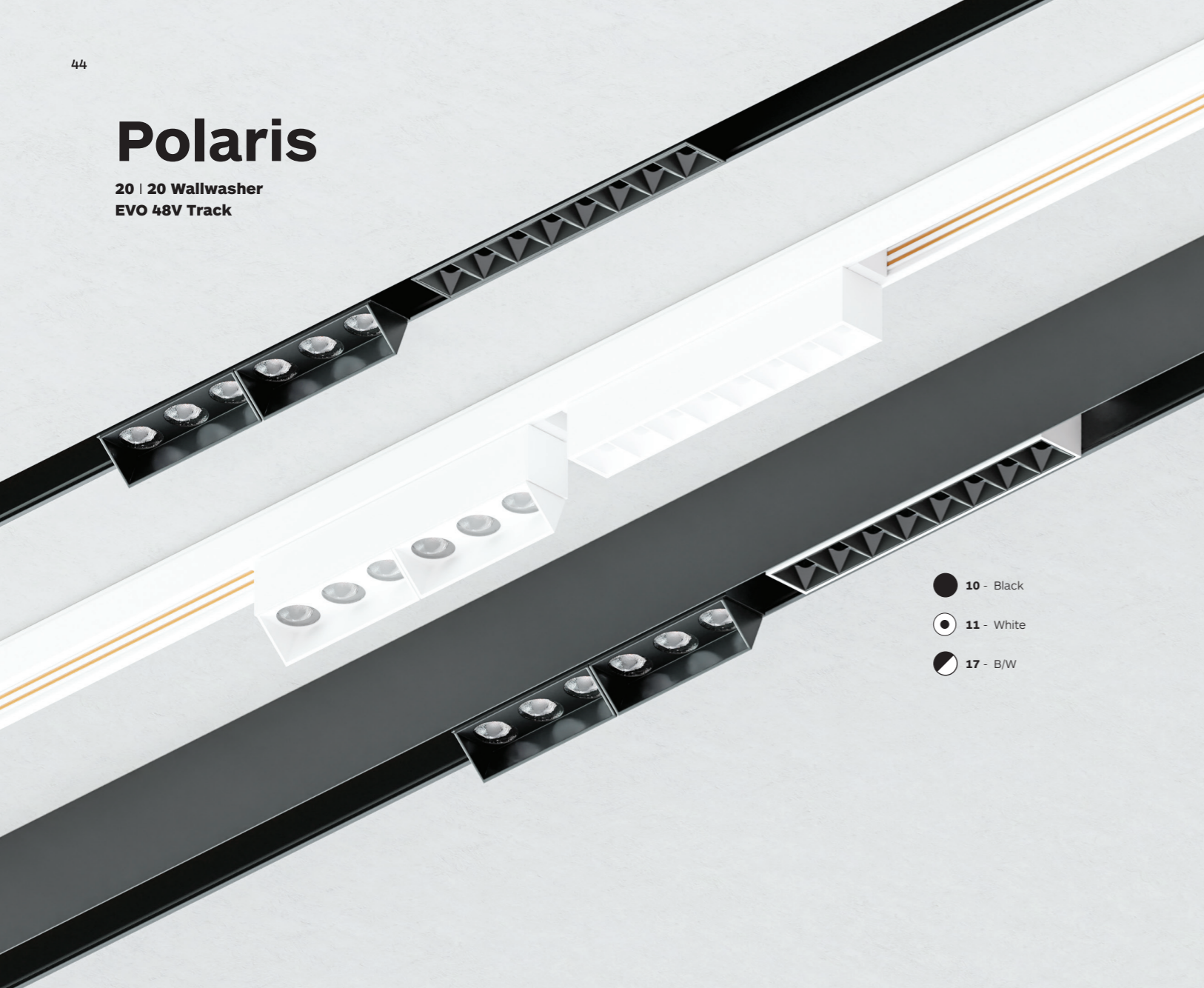

- 10 - Black
- 11 - White
- 17 - B/W

Polaris 20 and Polaris 20 wallwasher compact design linear spotlight, for EVO 48V track and deep recessed track.

The standard version is inclusive of an integrated diamond faceted no-dazzle screen in thermoplastic. The wallwasher version is inclusive of the integrated louvre.

Integrated track adapter, compatible with different models of EVO 48V track system. Easy to insert and remove from the track. Available in different configurations.

DALI dimmable fixtures can also be controlled by Casambi DALI Broadcast device, please see pages 66-67 for details.

For complete code ordering information, please see page 85.

**LED Sources:**

High Efficacy:  
CRI: 90 | CCT: 2700K, 3000K, 3500K, 4000K, Tuneable White.

**Accessories:**

For more information about EVO 48V track accessories see pages 66-73.

## Polaris 20 & Polaris 20 Wallwasher

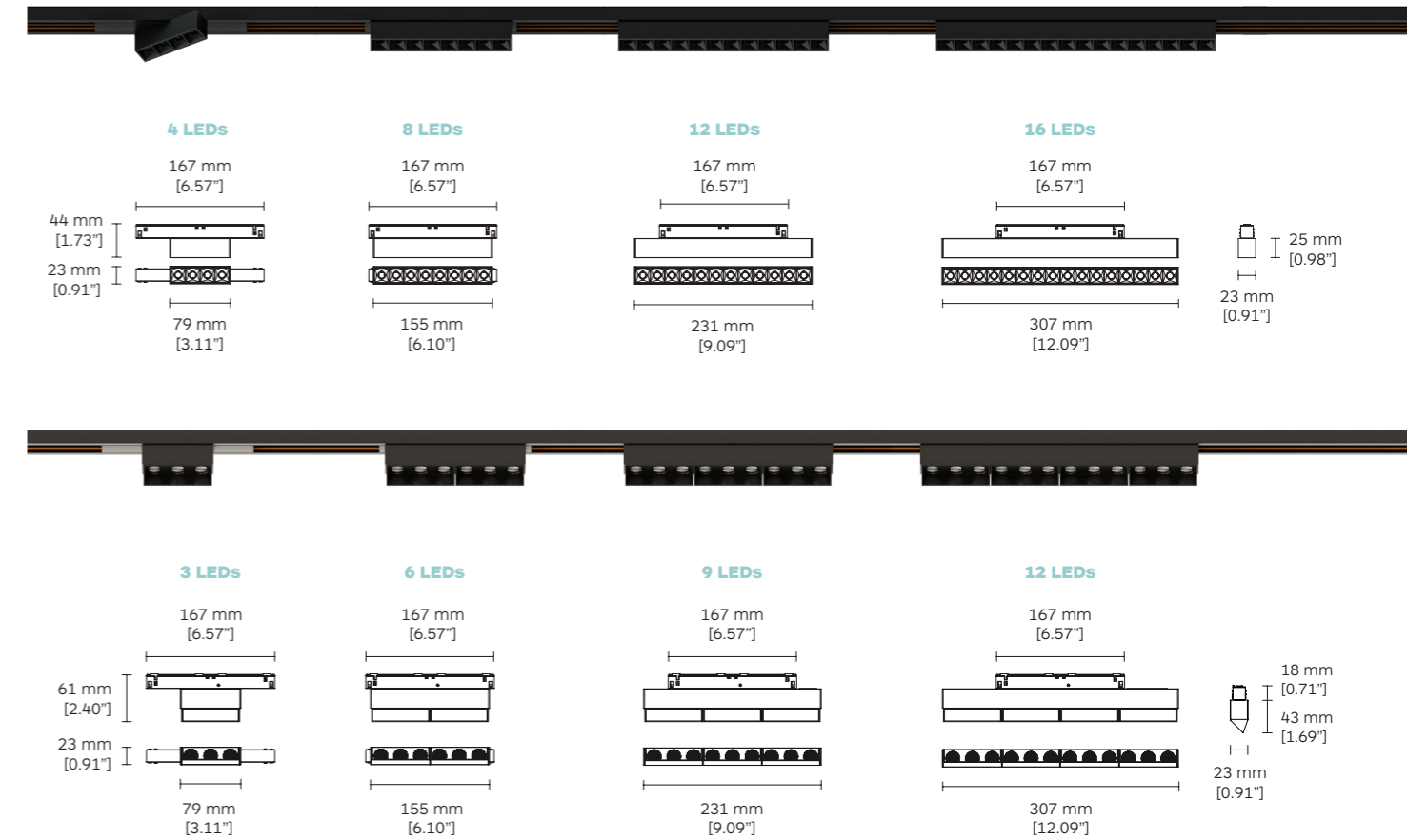
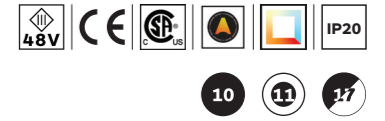

|  | Product Code                       | LED Source Code | LED Power           | Nominal Lumen | Beam Angle (BA°)             | Dimming Options                    |
|--|------------------------------------|-----------------|---------------------|---------------|------------------------------|------------------------------------|
| <b>CRI&gt;90</b><br><b>3000K</b><br><b>High Efficacy</b> | Polaris 20 with 4 LEDs             | <b>9601</b>     | <b>BO11</b><br>4x1W | 520 lm        | <b>21° / 30° / 45° / 60°</b> | <b>DO</b> No Dim                   |
|  | Polaris 20 with 8 LEDs             | <b>9602</b>     | 8x1W                | 1040 lm       |                              | <b>DA</b> Dali Dim                 |
|  | Polaris 20 with 12 LEDs            | <b>9603</b>     | 12x1W               | 1560 lm       |                              | <b>DC</b> CASAMBI                  |
|  | Polaris 20 with 16 LEDs            | <b>9604</b>     | 16x1W               | 2080 lm       |                              |                                    |
|  | Polaris 20 Wallwasher with 3 LEDs  | <b>9626</b>     | <b>BN11</b><br>4.2W | 525 lm        | <b>WW</b>                    | CCT Options                        |
|  | Polaris 20 Wallwasher with 6 LEDs  | <b>9627</b>     | 8.4W                | 1050 lm       |                              | <b>27</b> 2700K                    |
|  | Polaris 20 Wallwasher with 9 LEDs  | <b>9628</b>     | 12.6W               | 1575 lm       |                              | <b>30</b> 3000K                    |
|  | Polaris 20 Wallwasher with 12 LEDs | <b>9629</b>     | 16.8W               | 2100 lm       |                              | <b>35</b> 3500K<br><b>40</b> 4000K |

WW = Wallwasher. Ordering code: **WW**.  
Tuneable White (**TW**) version available on request.

# Polaris 20 Opal Diffuser

EVO 48V Track

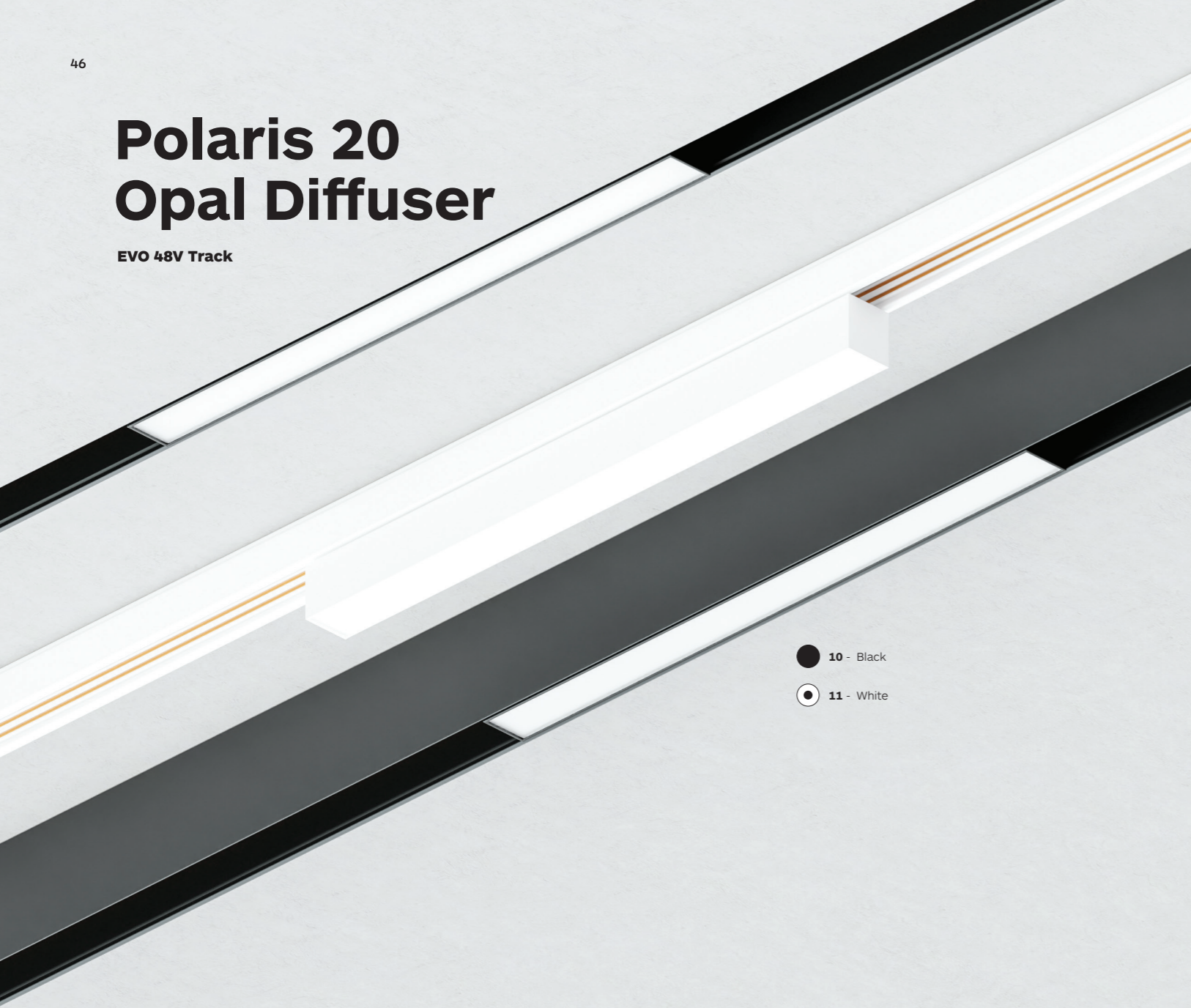

- 10 - Black
- 11 - White

Track mounted EVO 48V spotlight with light body in extruded aluminium inclusive of white opal diffuser for soft and diffuse illumination.

Integrated track adapter, compatible with different models of EVO 48V track system.

Easy to insert and remove from the track.

DALI dimmable fixtures can also be controlled by Casambi DALI Broadcast device, please see pages 66-67 for details.

For complete code ordering information, please see page 85.

**LED Sources:**

High Rendering:  
CRI: 97 | CCT: 2700K, 3000K, 3500K, 4000K,  
Tunable White.

**Accessories:**

For more information about EVO 48V track accessories see pages 66-73.

# Polaris 20 Opal Diffuser

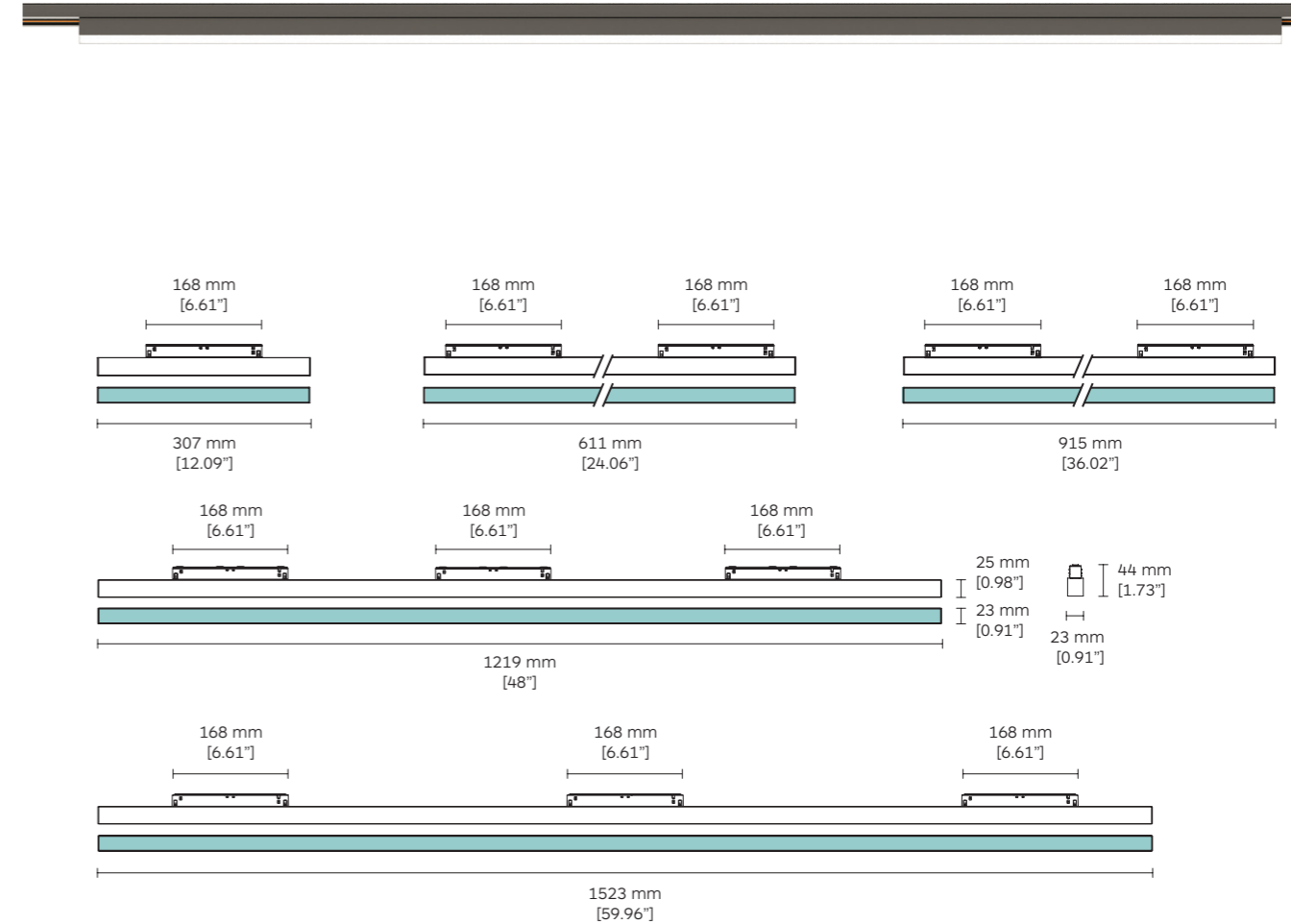

|   | Product Code                    | LED Source Code | LED Power           | Nominal Lumen | Diffuser  | Dimming Options       | CCT Options     |
|---|---------------------------------|-----------------|---------------------|---------------|-----------|-----------------------|-----------------|
| <b>CRI&gt;97<br/>3000K<br/>High Rendering</b> | Polaris 20 Opal Diffuser L:307  | <b>9676</b>     | <b>BT21</b><br>7.4W | 945 lm        | <b>OD</b> | <b>DO</b> No Dim      | <b>27</b> 2700K |
|   | Polaris 20 Opal Diffuser L:611  | <b>9677</b>     | 15W                 | 1890 lm       |           | <b>DA</b> Dali Dim    | <b>30</b> 3000K |
|   | Polaris 20 Opal Diffuser L:915  | <b>9678</b>     | 22W                 | 2835 lm       |           | <b>DC</b> CASAMBI     | <b>35</b> 3500K |
|   | Polaris 20 Opal Diffuser L:1219 | <b>9679</b>     | 30W                 | 2780 lm       |           | <b>40</b> 4000K       |                 |
|   | Polaris 20 Opal Diffuser L:1523 | <b>9680</b>     | 37W                 | 4725 lm       |           | <b>TW</b> 2700K-5700K |                 |

OD = Opal diffuser. Ordering code; **OD**.  
Tunable White (**TW**) version available on request.

# Polaris 20 Adjustable

EVO 48V Track



- 10 - Black
- 11 - White
- 17 - B/W

Polaris 20 adjustable spotlight with light body and arm in extruded aluminium inclusive of Integrated diamond faceted no-dazzle screen in thermoplastic. Integrated track adapter, compatible with different models of EVO 48V system. Custom size configuration is available in a multiple of 4 x LED (78mm).

Easy to insert and remove from the track. Versatile aiming angle tiltable vertically 90°.

Polaris 20 adjustable is available with CASAMBI and DALI control options. DALI dimmable fixtures can also be controlled by Casambi DALI Broadcast device, please see pages 66-67 for details.

For complete code ordering information, please see page 85.

**LED Sources:**

High Efficacy:  
CRI: 90 | CCT: 2700K, 3000K, 3500K, 4000K, Tuneable White.

**Accessories:**

For more information on about EVO 48V track accessories see pages 66-73.

# Polaris 20 Adjustable

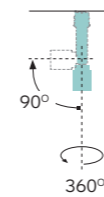
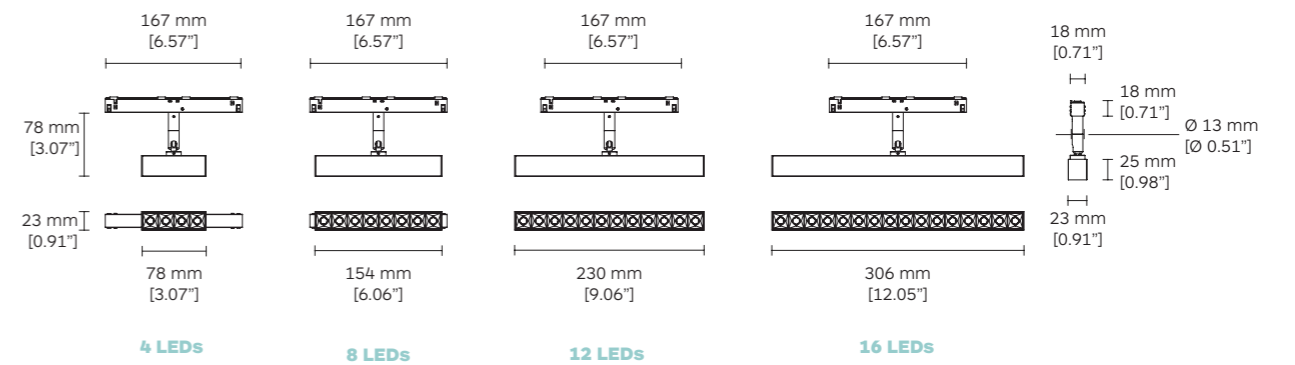

|  | Product Code                       | LED Source Code | LED Power   | Nominal Lumen | Beam Angle (BA°) | Dimming Options                    | CCT Options                      |
|--|------------------------------------|-----------------|-------------|---------------|------------------|------------------------------------|----------------------------------|
| <b>CRI &gt; 90</b><br><b>3000K</b><br><b>High Efficacy</b> | Polaris 20 Adjustable with 4 LEDs  | <b>9635</b>     | <b>BO11</b> | 4x1W          | 520 lm           | <b>21° / 30° / 45° / 60°</b>       | <b>DO</b> No Dim <b>27</b> 2700K |
|  | Polaris 20 Adjustable with 8 LEDs  | <b>9636</b>     |             | 8x1W          | 1040 lm          | <b>DA</b> Dali Dim <b>30</b> 3000K |                                  |
|  | Polaris 20 Adjustable with 12 LEDs | <b>9637</b>     |             | 12x1W         | 1560 lm          | <b>DC</b> CASAMBI <b>35</b> 3500K  |                                  |
|  | Polaris 20 Adjustable with 16 LEDs | <b>9638</b>     |             | 16x1W         | 2080 lm          | <b>40</b> 4000K                    |                                  |

Tuneable White (TW) version available on request.

# Filo

EVO 48V Track



- 10 - Black
- 11 - White

Filo is a technically and aesthetically innovative panel light solution, with an opal front cover, Ø200mm and merely 19 mm thick, and offers homogenous lighting with high intensity. Vertically tiltable 0°-55 and available in regular and deep recessed and pendant EVO 48V track.

Filo's custom engraving algorithm ensures 97% homogeneity of light in an aluminum protective housing and a transparent laser-processed methacrylate plate.

DALI dimmable fixtures can also be controlled by Casambi DALI Broadcast device, please see pages 66-67 for details.

For complete code ordering information, please see page 85.

**LED Sources:**

High Rendering:  
CRI: 97 | CCT: 2700K, 3000K, 3500K, 4000K.

**Accessories:**

For more information about EVO 48V track accessories see pages 66-73.

# Filo

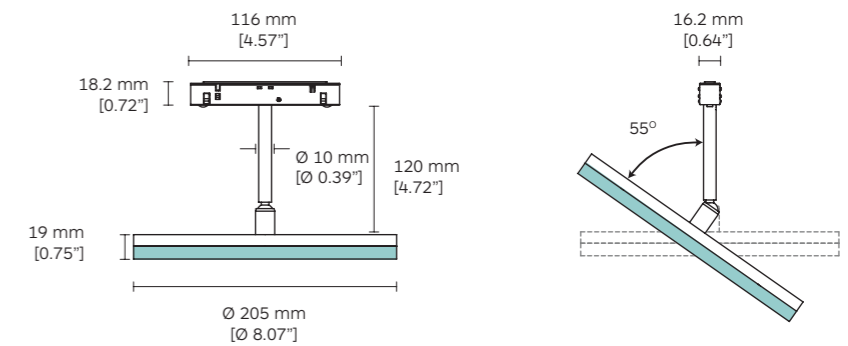
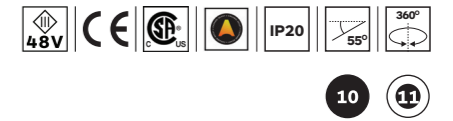

**CRI > 97**  
**3000K**  
High  
Rendering

| Product Code | LED Source Code | LED Power   | Nominal Lumen | Diffuser | Dimming Options    | CCT Options                      |
|--------------|-----------------|-------------|---------------|----------|--------------------|----------------------------------|
| Filo 200     | <b>9675</b>     | <b>002Y</b> | 9.4W          | 439 lm   | <b>OD</b>          | <b>D0</b> No Dim <b>27</b> 2700K |
|              |                 |             |               |          | <b>DA</b> Dali Dim | <b>30</b> 3000K                  |
|              |                 |             |               |          | <b>DC</b> CASAMBI  | <b>35</b> 3500K                  |
|              |                 |             |               |          |                    | <b>40</b> 4000K                  |

OD = Opal diffuser. Ordering code: **OD**.

# Polaris

EVO 48V Track Pendant

- 10 - Black
- 11 - White
- 17 - B/W

Pendant luminaire for EVO 48V track systems with light body in extruded aluminium inclusive of integrated diamond faceted no-dazzle screen in thermoplastic. Two standard lengths in 687mm and 915mm; custom size configuration is available in a multiple of 4 x LED (78mm).

Supplied with integrated track adapter, compatible with different models of EVO 48V track system, and 2 x 1.5m pendant wires.

Polaris EVO 48V Track Pendant is available with CASAMBI and DALI control options. DALI dimmable fixtures can also be controlled by Casambi DALI Broadcast device, please see pages 66-67 for details.

For complete code ordering information, please see page 85.

**LED Sources:**

High Efficacy:  
CRI: 90 | CCT: 2700K, 3000K, 3500K, 4000K.

**Accessories:**

For more information about EVO 48V track accessories see pages 66-73.

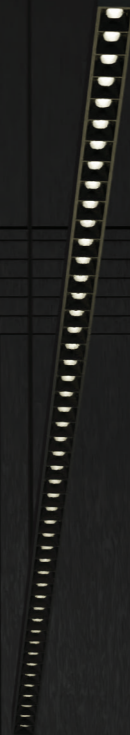

# Polaris

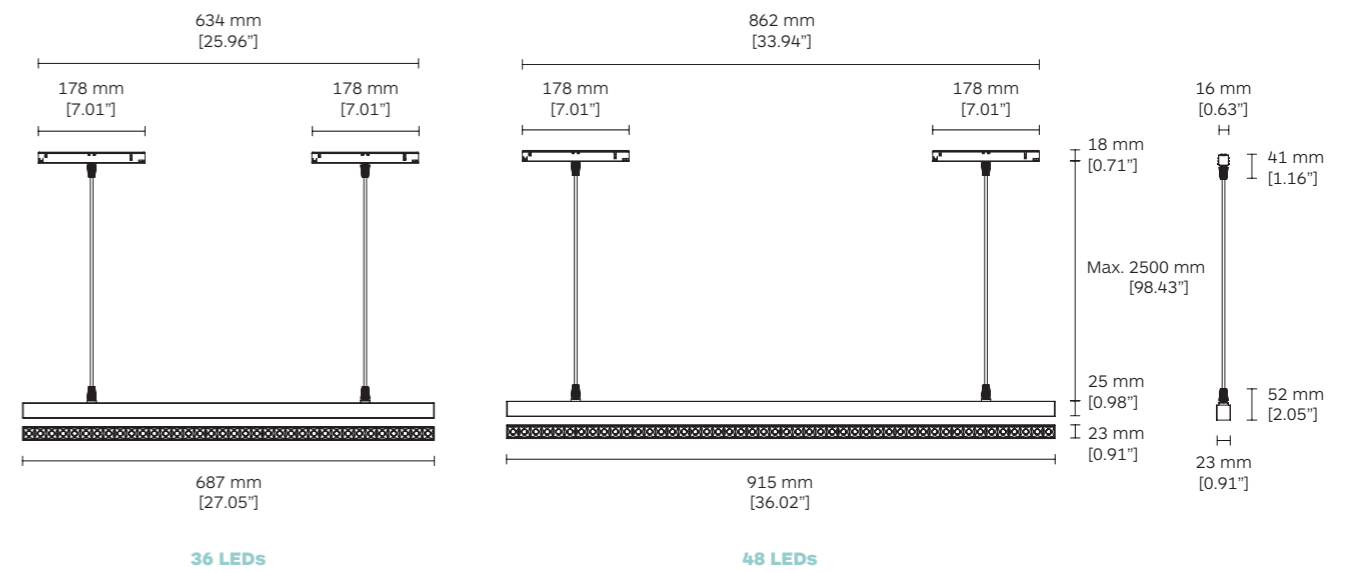

CRI > 90  
3000K  
High Efficacy

| Product Code | LED Source Code | LED Power | Nominal Lumen | Beam Angle (BA°)      | Dimming Options | CCT Options |
|--------------|-----------------|-----------|---------------|-----------------------|-----------------|-------------|
| 9712         | BO11            | 36x1W     | 4680 lm       | 21° / 30° / 45° / 60° | DO No Dim       | 27 2700K    |
| 9713         |                 | 48x1W     | 6240 lm       |                       | DA Dali Dim     | 30 3000K    |
|              |                 |           |               |                       | DC CASAMBI      | 35 3500K    |
|              |                 |           |               |                       |                 | 40 4000K    |

# Polaris Opal Diffuser

EVO 48V Track Pendant

- 10 - Black
- 11 - White

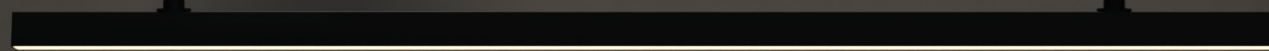

Pendant luminaire for EVO 48V track systems with light body in extruded aluminium inclusive of white opal diffuser for soft and diffuse illumination.

Supplied with integrated track adapter, compatible with different models of EVO 48V track system, and 2 x 1.5m pendant wires.

Polaris Opal Diffuser Pendant is available with CASAMBI and DALI control options. DALI dimmable fixtures can also be controlled by Casambi DALI Broadcast device, please see pages 66-67 for details.

For complete code ordering information, please see page 85.

**LED Sources:**

High Rendering:  
CRI: 97 | CCT: 2700K, 3000K, 3500K, 4000K.

**Accessories:**

For more information about EVO 48V track accessories see pages 66-73.

# Polaris 20 Opal Diffuser

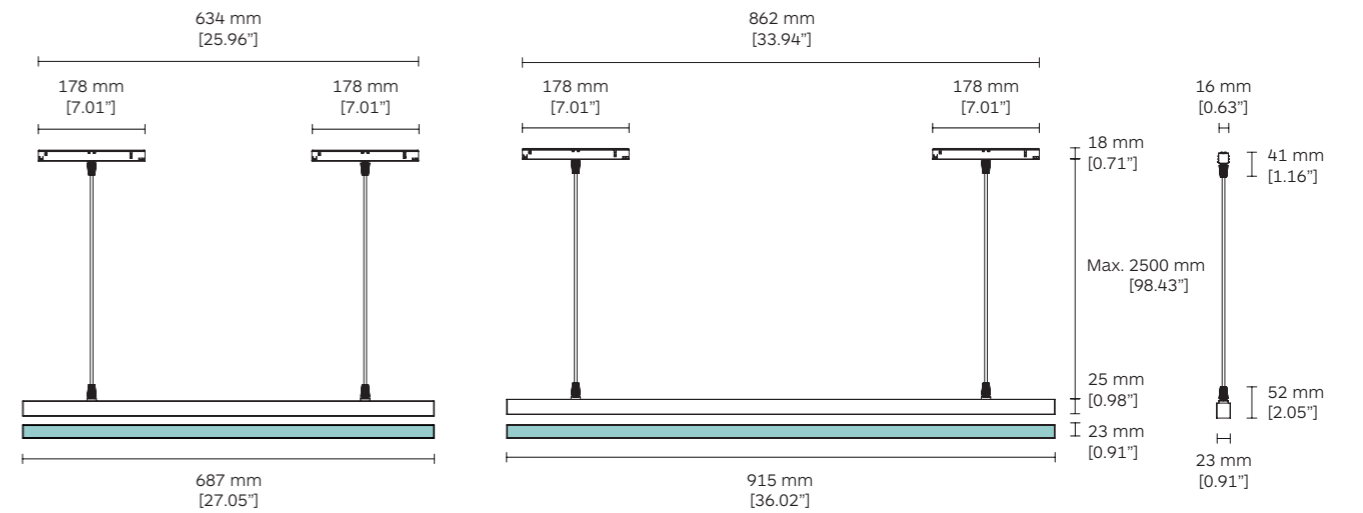

|   | Product Code                           | LED Source Code | LED Power   | Nominal Lumen | Diffuser | Dimming Options                         | CCT Options   |
|---|--|-----------------|-------------|---------------|----------|---|---|
| <b>CRI&gt;97</b><br><b>3000K</b><br><b>High Rendering</b> | Polaris 20 Opal Diffuser Pendant L:687 | <b>9724</b>     | <b>BT21</b> | 16W           | 2079 lm  | <b>OD</b>                               | <b>27</b> 2700K                                       |
|   | Polaris 20 Opal Diffuser Pendant L:915 | <b>9726</b>     |             | 22W           | 2835 lm  | <b>DA</b> Dali Dim<br><b>DC</b> CASAMBI | <b>30</b> 3000K<br><b>35</b> 3500K<br><b>40</b> 4000K |

OD = Opal diffuser. Ordering code: **OD**.

# Pixxo Retro

25 | 38  
EVO 48V Track

Pixxo Retro offers both classic filament ambient light and modern accent light. LED filament light is designed to resemble a traditional incandescent light bulb with visible filaments for aesthetic and create ambient; the spotlight with multiple beam angle options provides functional accent lighting.

Clean product design with a clear glass body and extruded aluminum, available in two different diameters Ø25mm Ø38mm, and two different lengths.

Pixxo Retro available with Casambi and DALI control options. DALI dimmable fixtures can also be controlled by Casambi DALI Broadcast device, please see pages 66-67 for details.

For complete code ordering information, please see page 85.

**LED Sources:**

Ambient light:  
CRI: 80 | CCT: 2700K, 3000K, 3500K, 4000K.

Spot light:  
High Efficacy  
CRI: 90 | CCT: 2700K, 3000K, 3500K, 4000K.

**Accessories:**

For more information about EVO 48V track accessories see pages 66-73.

- 10 - Black
- 65 - Embossed matt black
- 11 - White
- 54 - Embossed matt white

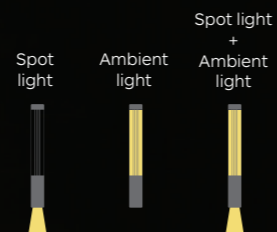

# Pixxo Retro

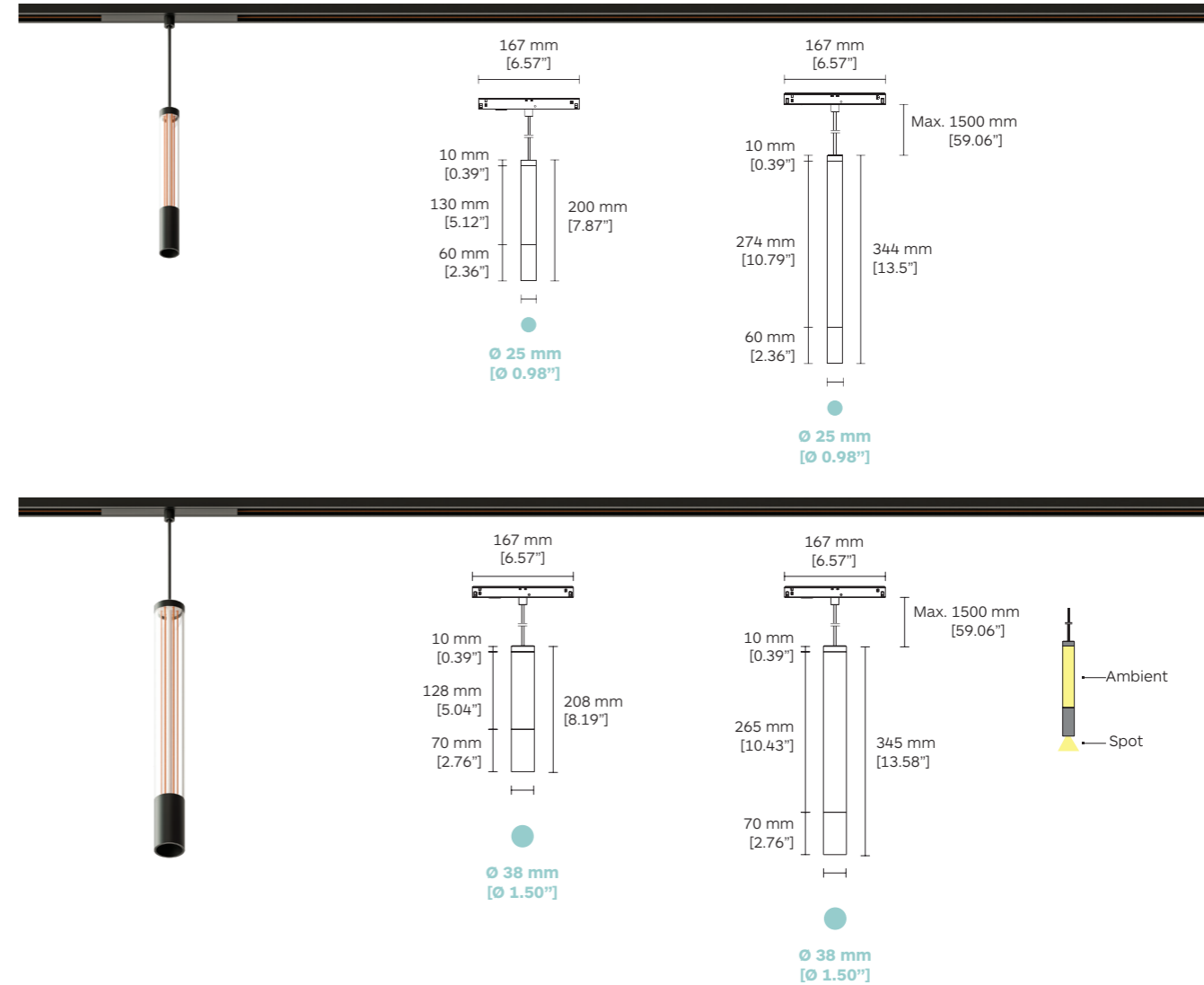

| Product Code         | Length Cable Code <sup>1</sup> | LED Power <sup>2</sup> |                | Nominal Lumen     |                | Beam Angle (BA°) | Dimming Options |
|----------------------|--------------------------------|------------------------|----------------|-------------------|----------------|------------------|-----------------|
|                      |                                | Ambient<br>CRI>80      | Spot<br>CRI>90 | Ambient<br>CRI>80 | Spot<br>CRI>90 |                  |                 |
| Pixxo Retro 25 L:200 | 9656                           | Min. 0100              | 4.9W           | /                 | 397 lm         | /                | DA Dali Dim     |
| Pixxo Retro 25 L:344 | 9657                           | ⋮                      | /              | 2.6W              | /              | 16° / 20° / 34°  | DC CASAMBI      |
|                      |                                | Max. 1500              |                |                   |                |                  | CCT Options     |
| Pixxo Retro 38 L:208 | 9658                           |                        | 4.9W           | /                 | 397 lm         | /                | 27 2700K        |
| Pixxo Retro 38 L:345 | 9659                           |                        | /              | 6.7W              | /              | 723 lm / 780 lm  | 30 3000K        |
|                      |                                |                        |                |                   |                |                  | 35 3500K        |
|                      |                                |                        |                |                   |                |                  | 40 4000K        |

<sup>1</sup> Length cable code from 100mm up to 1500mm. Example: 0750.  
<sup>2</sup> 2 control channels, spot light and ambient light can be controlled separately.

# Pixxo

25 | 38  
EVO 48V Track

Pendant luminaire for EVO 48V track systems with lightbody in extruded aluminum. Light body available in two sizes (Ø25 and Ø36mm) and different lengths, to fit any ceiling height.

Supplied with integrated track adapter, compatible with different models of EVO 48V track system, inclusive of 2 x 1.5m pendant wires.

DALI dimmable fixtures can also be controlled by Casambi DALI Broadcast device, please see pages 66-67 for details.

For complete code ordering information, please see page 85.

**LED Sources:**

High Efficacy:  
CRI: 90 | CCT: 2700K, 3000K, 3500K, 4000K.

**Accessories:**

For more information about EVO 48V track accessories see pages 66-73.

- 10 - Black
- 65 - Embossed matt black
- 11 - White
- 54 - Embossed matt white



# Pixxo

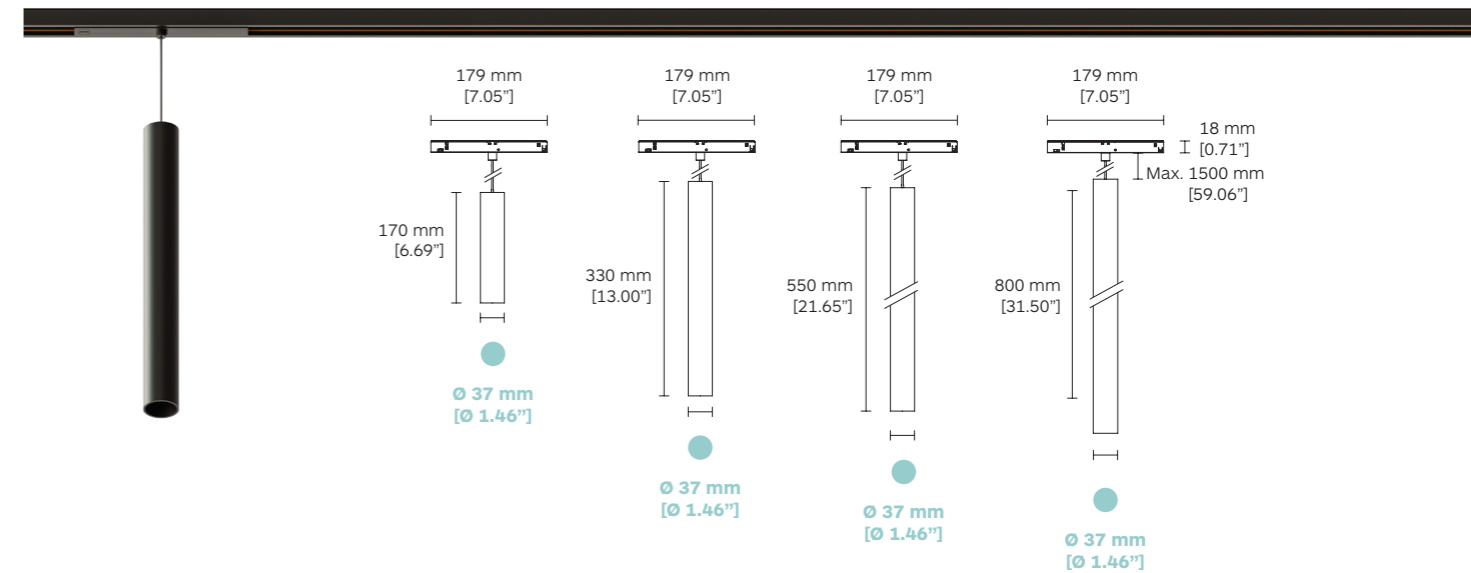
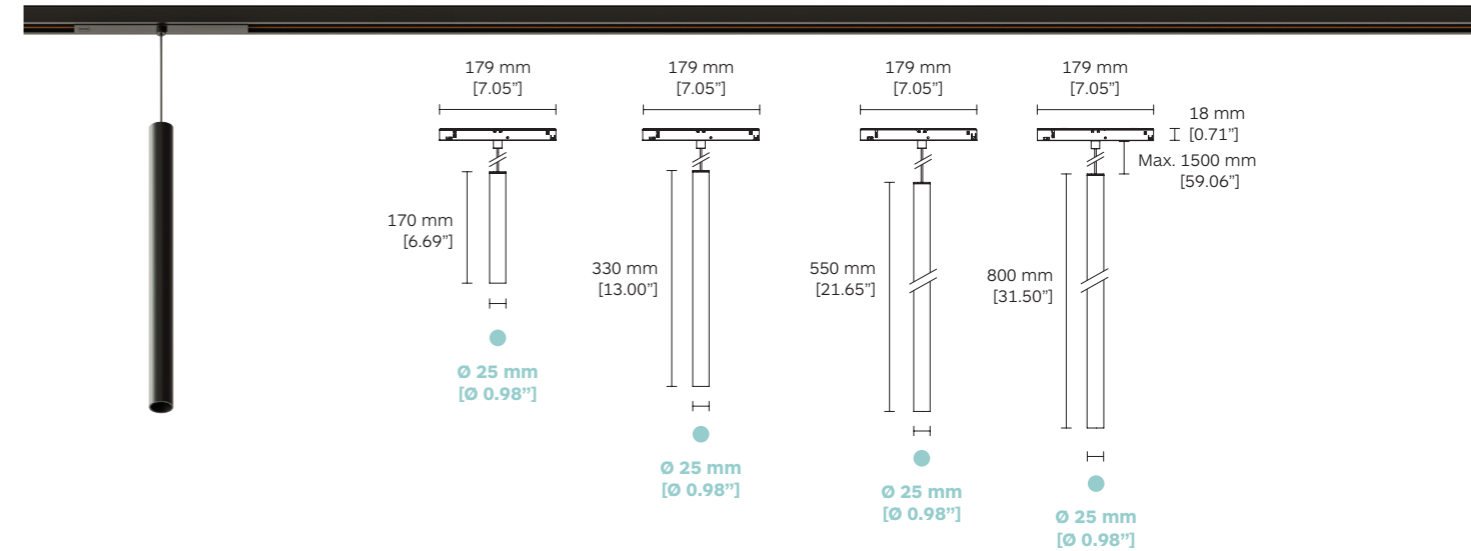

CRI > 90  
3000K  
High Efficacy

|                | Product Code | LED Source Code | LED Power | Nominal Lumen | Beam Angle (BA°)       |
|----------------|--------------|-----------------|-----------|---------------|------------------------|
| Pixxo 25 L:170 | <b>9703</b>  | <b>BR21</b>     | 2.8W      | 333 lm        | <b>15° / 20° / 32°</b> |
| Pixxo 25 L:330 | <b>9704</b>  |                 |           |               |                        |
| Pixxo 25 L:550 | <b>9705</b>  |                 |           |               |                        |
| Pixxo 25 L:800 | <b>9706</b>  |                 |           |               |                        |
| <hr/>          |              |                 |           |               |                        |
| Pixxo 36 L:170 | <b>9707</b>  | <b>BC35</b>     | 5W        | 517 lm        | <b>20° / 26° / 36°</b> |
| Pixxo 36 L:330 | <b>9708</b>  |                 |           |               |                        |
| Pixxo 36 L:550 | <b>9709</b>  |                 |           |               |                        |
| Pixxo 36 L:800 | <b>9710</b>  |                 |           |               |                        |

- Dimming Options**
- D0** No Dim
  - DA** Dali Dim
  - DC** CASAMBI

- CCT Options**
- 27** 2700K
  - 30** 3000K
  - 35** 3500K
  - 40** 4000K

# Lucciole

## EVO 48V Track

The Lucciole series for EVO 48V track offers a classic & elegant Italian-designed pendant mounted decorative lighting system. It features integrated track adapter, mounts the decorative lamp using suspension cables of length 1500mm (max) with a very easy installation process.

Inspired by a firefly's ability of natural glow, it features suspension lamps of various shapes, sizes, and designs. An eco-friendly and 100% recyclable lamp with diffused light distribution.

DALI dimmable fixtures can also be controlled by Casambi DALI Broadcast device, please see pages 66-67 for details.

For complete code ordering information, please see page 85.

### LED Sources:

High Efficacy:  
CRI: 90 | CCT: 2700K, 3000K, 3500K, 4000K.

### Accessories:

For more information about EVO 48V track accessories see pages 66-73.

● 10 - Black

○ 11 - White



# Lucciole

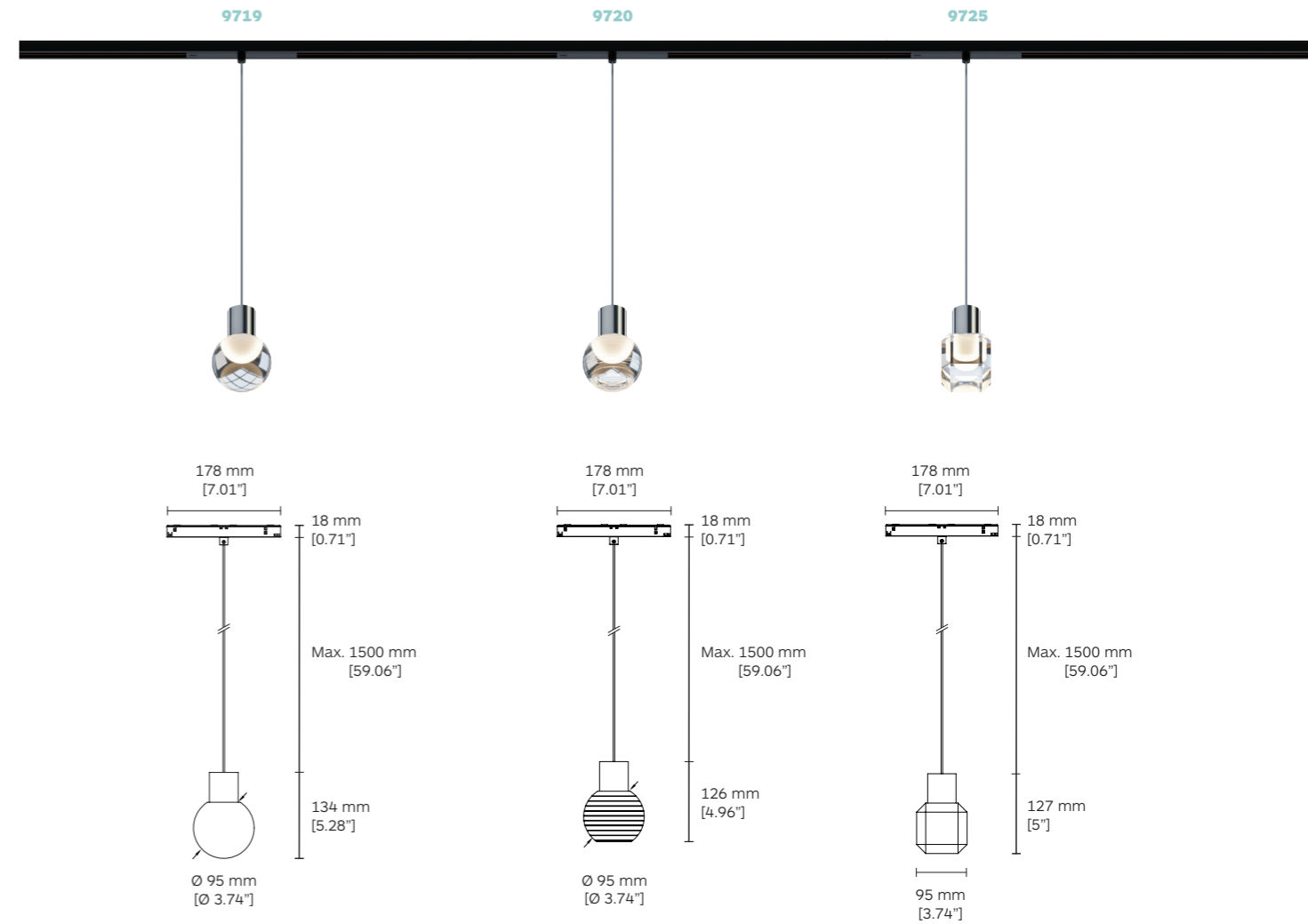

|  | Product Code         | LED Source Code | LED Power | Nominal Lumen | Diffuser  | Dimming Options           | CCT Options   |
|--|----------------------|-----------------|-----------|---------------|-----------|---------------------------|---|
| <b>CRI&gt;90</b><br><b>3000K</b><br><b>High Efficacy</b> | Lucciole <b>9719</b> | <b>BB32</b>     | 6.5W      | 724 lm        | <b>TD</b> | <b>DC</b> CASAMBI         | <b>27</b> 2700K   |
|  | Lucciole <b>9720</b> |                 |           |               |           | <b>DN</b> On-board Dimmer | <b>30</b> 3000K   |
|  | Lucciole <b>9725</b> |                 |           |               |           |                           | <b>35</b> 3500K<br><b>40</b> 4000K<br><b>DW</b> 3000K-1800K |

TD = Transparent lenticular diffuser. Ordering code; **TD**.

# Optical Accessories



| Product /<br>Optical Accessories  | Coloured<br>Glasses Diffuser<br>25, 42, 55, 85 | Opal<br>Lens<br>Colour 41 | Spread<br>Lens<br>Colour 41 | Elliptical<br>Beam Diffuser<br>Colour 41 | Wide Texture<br>Honeycomb Louvre<br>Colour 10 |
|-----------------------------------|--|---------------------------|-----------------------------|--|---|
| TicTok 25 & Viivo 25              | <b>2G57</b>                                    | <b>2G59</b>               | /                           | <b>2G61</b>                              | <b>2G30</b>                                   |
| TicTok 35 & Viivo 35              | <b>2G58</b>                                    | <b>2G60</b>               | /                           | <b>2G62</b>                              | <b>2G31</b>                                   |
| TicTok 45 <sup>1</sup> & Viivo 45 | <b>2F91</b>                                    | <b>2F94</b>               | <b>2F97</b>                 | <b>2F88</b>                              | <b>2F71</b>                                   |
| TicTok 58 <sup>1</sup> & Viivo 58 | <b>2F92</b>                                    | <b>2F95</b>               | <b>2F98</b>                 | <b>2F89</b>                              | <b>2F83</b>                                   |
| TicTok 75 & Viivo 75              | <b>2F93</b>                                    | <b>2F96</b>               | <b>2F99</b>                 | <b>2F90</b>                              | <b>2F84</b>                                   |



| Product /<br>Optical Accessories  | Dense Texture<br>Honeycomb Louvre<br>Colour 10 | Cross blade<br>Louvre<br>Colours 10, 17 | Barn<br>Doors<br>Colours 10, 11 | Wallwasher<br>Cone 45°<br>Colours 10, 17 |
|-----------------------------------|--|---|---------------------------------|--|
| TicTok 25 & Viivo 25              | <b>2G32</b>                                    | /                                       | /                               | /  |
| TicTok 35 & Viivo 35              | <b>2G33</b>                                    | /                                       | /                               | /  |
| TicTok 45 <sup>1</sup> & Viivo 45 | <b>2F85</b>                                    | <b>2G01</b>                             | <b>2G04</b>                     | <b>2G07</b>                              |
| TicTok 58 <sup>1</sup> & Viivo 58 | <b>2F86</b>                                    | <b>2G02</b>                             | <b>2G05</b>                     | <b>2G08</b>                              |
| TicTok 75 & Viivo 75              | <b>2F87</b>                                    | <b>2G03</b>                             | <b>2G06</b>                     | <b>2G09</b>                              |

## Notes:

<sup>1</sup> No optical accessories are available for TicTok 45, 58 Zoom series.

# Optical Accessories

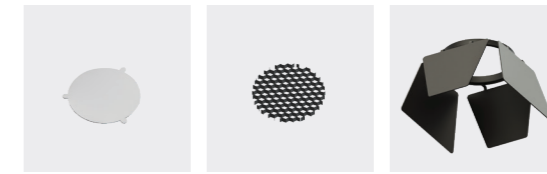

| Product /<br>Optical Accessories | Filter<br>Colour 10 | Honeycomb<br>Colour 10 | Barn Doors<br>Colours 10, 11 |
|----------------------------------|---------------------|------------------------|------------------------------|
| Zero 33                          | <b>G2A6</b>         | <b>G2A7</b>            | <b>G2A1</b>                  |
| Zero 33 Long Arm                 |                     |                        |                              |



| Product / Optical Accessories     | Coloured Filters<br>Colours 25, 42, 55, 85 | Linear Spread<br>Colour 41 | Honeycomb Louvre<br>Colour 10 | Visor<br>Colours 10, 17 | Anti-glare Tube<br>Colours 10, 17 |
|-----------------------------------|--|----------------------------|-------------------------------|-------------------------|-----------------------------------|
| Zero 40 & Zero 40 with Long Arm   | <b>2E36*</b>                               | <b>2E44*</b>               | <b>2E35</b>                   | /                       | <b>2E43</b>                       |
| Zero 66 & Zero 66 with Long Arm   | <b>2D63*</b>                               | <b>2D62*</b>               | <b>2C65</b>                   | <b>2D94</b>             | <b>2D67</b>                       |
| Zero 100 & Zero 100 with Long Arm | <b>2E10*</b>                               | <b>2E12*</b>               | <b>2C66</b>                   | <b>2E14</b>             | <b>2E16</b>                       |

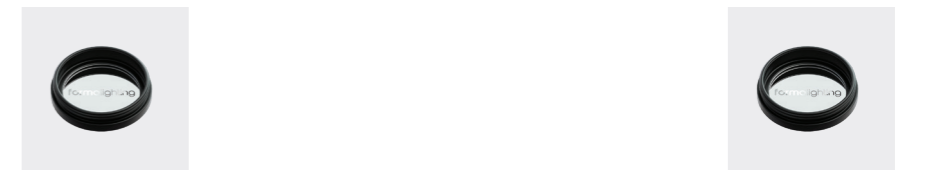

| Product /<br>Optical Accessories | Gobo film<br>Colour 10 | Product /<br>Optical Accessories | Gobo film<br>Colour 10 |
|----------------------------------|------------------------|----------------------------------|------------------------|
| Zero Framing Projector 28        | <b>2G92</b>            | Zero Framing Projector 38        | <b>2G24</b>            |

## Notes:

\* With holder

# TicTok & Viivo

The circular series



TicTok provides innovation leadership with the new Eterno technology. The easy to change COB module provides a ready-to-use solution for greater flexibility, energy efficiency, and sustainability.

# LED Modules & Lens compatibility

For TicTok & Viivo products

| Product compatibility                         | LED Module                                | CRI   | LED Power         | LENS Compatibility Code |           |                |                       |           |      |
|---|---|---|-------------------|-------------------------|-----------|----------------|-----------------------|-----------|------|
|   |   |   |                   | 15°                     | 20°       | 32°            |                       |           |      |
| <b>TicTok 25</b><br>Codes: 96B2   96C3        | <b>E017</b>                               | <b>CRI 90</b>                                   | 3.4W              | L021                    | L022      | L023           |                       |           |      |
| <b>Viivo 25</b><br>Codes: 96A8   96C8         |   |   |                   |                         |           |                |                       |           |      |
| <b>TicTok 35</b><br>Codes: 96B3   96C4        | <b>E063</b><br><b>E013</b>                | <b>CRI 90</b><br><b>CRI 93</b>                  | 2.1W<br>5W        | L030<br>/               | /<br>L024 | /<br>L025      | /<br>L026             |           |      |
| <b>Viivo 35</b><br>Codes: 96A9   96C9         |   |   |                   |                         |           |                |                       |           |      |
| <b>TicTok 45</b><br>Codes: 9662   9663   96H8 | <b>E025</b><br><b>E051</b>                | <b>CRI 93</b><br><b>CRI 95</b><br><b>CRI 98</b> | 9W<br>8W          | /<br>L032               | /<br>/    | L014<br>/      | L015<br>/             | L016<br>/ |      |
| <b>Viivo 45</b><br>Codes: 96B0   96D0   96J1  | <b>E020</b>                               | <b>CRI 98</b>                                   | 9W                | /                       | L014      | L015           | L016                  |           |      |
| <b>TicTok 58</b><br>Codes: 9664   9665   96H9 | <b>E026</b><br><b>E031</b><br><b>E027</b> | <b>CRI 93</b><br><b>CRI 93</b><br><b>CRI 98</b> | 14W<br>15W<br>14W | /<br>L017<br>/          | L017<br>/ | /<br>L018<br>/ | L018<br>/             | L019<br>/ | L019 |
| <b>Viivo 58</b><br>Codes: 96B1   96D1   96J2  |   |   |                   |                         |           |                |                       |           |      |
| <b>TicTok 75</b><br>Codes: 9666   9667   96J0 | <b>E029</b><br><b>E006</b>                | <b>CRI 93</b><br><b>CRI 98</b>                  | 18W<br>18W        | L008<br>/               | /<br>L008 | L009<br>/      | L010<br>/             | /<br>L010 |      |
| <b>Viivo 75</b><br>Codes: 96C7   96D2   96J3  |   |   |                   |                         |           |                |                       |           |      |
| <b>TicTok 45 Zoom</b><br>Codes: 96A6   96C5   | <b>E009</b>                               | <b>CRI 90</b>                                   | 6W                |                         |           |                | <b>BS (12° - 37°)</b> |           |      |
| <b>TicTok 58 Zoom</b><br>Codes: 96A7   96C6   | <b>E004</b>                               | <b>CRI 93</b>                                   | 15W               |                         |           |                | <b>BS (17° - 27°)</b> |           |      |
| <b>TicTok 75 Zoom</b><br>Codes: 9668   9669   | <b>E035</b>                               | <b>CRI 93</b>                                   | 15W               |                         |           |                | <b>BS (17° - 27°)</b> |           |      |
| <b>Viivo 75 Zoom</b><br>Codes: 96D7   96D8    | <b>E035</b>                               | <b>CRI 93</b>                                   | 15W               |                         |           |                | <b>BS (17° - 27°)</b> |           |      |

# Casambi DALI Broadcast



# Casambi DALI Broadcast

## For EVO track 48VDC input

Casambi DALI Broadcast offers a cutting-edge solution for controlling wireless luminaires on low-voltage (48V) tracks.

Through Casambi Bluetooth Low Energy (BLE) communication with control apps, all you need is a smartphone or tablet to take charge of your lighting system.

Imagine having complete control over the lighting in your space without the hassle of wiring, control units, or routers. With Casambi Broadcast technology, this dream is now a reality.

Add a Casambi DALI broadcast device (9269) directly to EVO 48V track, and select a product with a DALI driver included (DA).

## Group Configuration - up to 64 luminaires

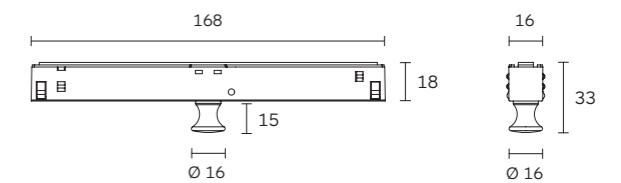
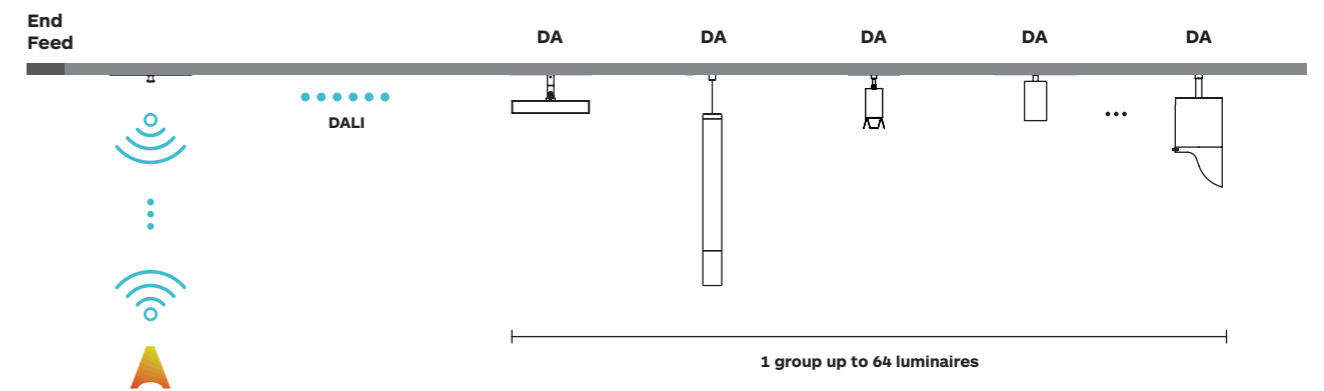

### Wireless control device

| Code:                            | 9269           |
|----------------------------------|----------------|
| Nominal Input Voltage:           | 24-50 Vdc      |
| Current:                         | 48V - 0.06 A   |
| Output Voltage:                  | 18 - 18.5 V DC |
| Output current in short circuit: | 200 mA         |
| Output channel:                  | 1              |
| Management protocol:             | DALI           |

# EVO 48V Track Options

## Recessed Trim Track

2ST8 + Art. 9202 Bracket with spring for 2ST8 included

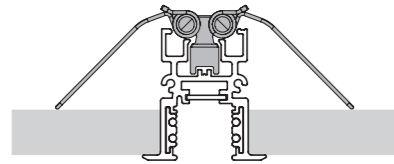

## Recessed Trimless Track

2ST3 + Art. 9201 Bracket for 2ST3 trimless track included

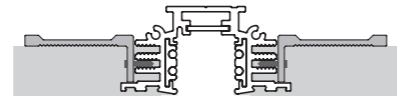

## Deep Recessed Trim Track

2ST5

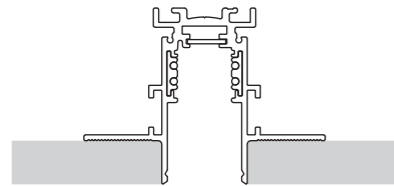

## Deep Recessed Trimless Track

2STA

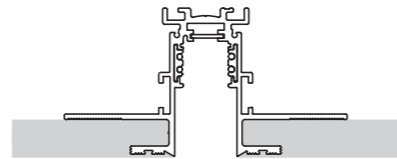

## Deep Recessed Track Trim

2STK

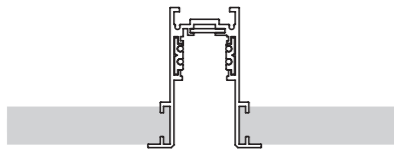

## Pendant Track

2ST6 + Pendant Kits Art.9226

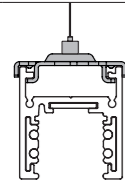

2ST2 + Deep Pendant Kits Art.9226

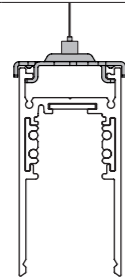

2ST7 + Pendant Kits Art.9226

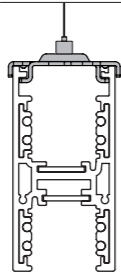

2ST9 + Deep Pendant Kits Art.9226

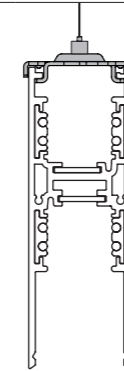

2ST4 + Straight Connector with Wire Hanger for Track Art.9284

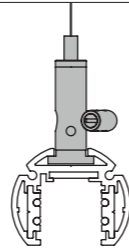

## Pendant Kit

Pendant Kit Art. 9226

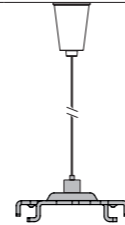

## Surface Track

2ST6 + Surface Kits Art.9225

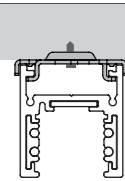

2ST2 + Deep Surface Kits Art.9225

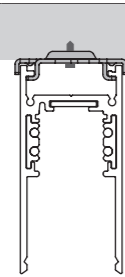

2ST1

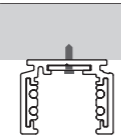

2ST4 + Pendant Rod Art.9282

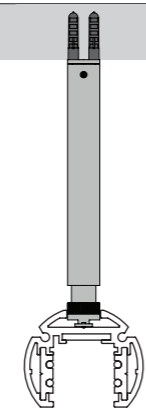

## Surface Kit

Surface Kit Art. 9225



# Compatibility

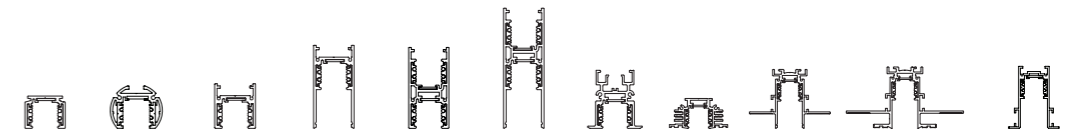

## Track Options/ Product name

|  | Surface Track | Surface / Pendant Track | Surface Track Pendant Track | Deep Surface Deep Pendant Track | Pendant Track     | Deep Pendant Track | Recessed Track Trim | Recessed Track Trimless | Deep Recessed Track Trim | Deep Recessed Track Trimless | Deep Recessed Track Trim |
|--|---------------|-------------------------|-----------------------------|---------------------------------|-------------------|--------------------|---------------------|-------------------------|--------------------------|------------------------------|--------------------------|
|  | 2ST1          | 2ST4                    | 2ST6                        | 2ST2                            | 2ST7<br>Up & Down | 2ST9<br>Up & Down  | 2ST8                | 2ST3                    | 2ST5                     | 2STA                         | 2STK                     |
| TicTok & Viivo<br>25 / 35 / 45 / 58 / 75   | ✓             | ✓                       | ✓                           |                                 | ✓                 | ✓                  | ✓                   | ✓                       |                          |                              |                          |
| TicTok & Viivo <b>Long Arm</b><br>25 / 35 / 45 / 58 / 75   | ✓             | ✓                       | ✓                           | ✓                               | ✓                 | ✓                  | ✓                   | ✓                       | ✓                        | ✓                            | ✓                        |
| TicTok & Viivo <b>Zoom</b><br>45 / 58 / 75   | ✓             | ✓                       | ✓                           |                                 | ✓                 | ✓                  | ✓                   | ✓                       |                          |                              |                          |
| TicTok & Viivo <b>Zoom Long Arm</b><br>45 / 58 / 75  | ✓             | ✓                       | ✓                           | ✓                               | ✓                 | ✓                  | ✓                   | ✓                       | ✓                        | ✓                            | ✓                        |
| TicTok & Viivo <b>Top Mounted</b><br>45 / 58 / 75  |               |                         |                             |                                 | ✓                 | ✓                  |                     |                         |                          |                              |                          |
| Zero Framing Projector<br>Zero Compasso Wallwasher<br>Zero 33 / 40 / 66 / 100<br>Zero <b>Zoom 80</b> |               | ✓                       | ✓                           |                                 | ✓                 | ✓                  | ✓                   | ✓                       |                          |                              |                          |
| Zero Framing Projector<br>Zero 33 / 40 / 66 / 100<br>Zero <b>Zoom 80 Long Arm</b>                    | ✓             | ✓                       | ✓                           | ✓                               | ✓                 | ✓                  | ✓                   | ✓                       | ✓                        | ✓                            | ✓                        |
| Polaris 20<br>Polaris 20 Wallwasher<br>Polaris 20 Opal Diffuser                                      | ✓             | ✓                       | ✓                           | ✓                               | ✓                 | ✓                  | ✓                   | ✓                       | ✓                        | ✓                            | ✓                        |
| Polaris 20 Adjustable  | ✓             | ✓                       | ✓                           | ✓                               | ✓                 | ✓                  | ✓                   | ✓                       | ✓                        | ✓                            | ✓                        |
| Filo   | ✓             | ✓                       | ✓                           | ✓                               | ✓                 | ✓                  | ✓                   | ✓                       | ✓                        | ✓                            | ✓                        |
| Polaris 20<br>Polaris 20 Opal Diffuser<br>Pendant  | ✓             | ✓                       | ✓                           | ✓                               | ✓                 | ✓                  | ✓                   | ✓                       | ✓                        | ✓                            | ✓                        |
| Pixxo Retro 25 & 38<br>Pixxo 25 & 36<br>Pendant  | ✓             | ✓                       | ✓                           | ✓                               | ✓                 | ✓                  | ✓                   | ✓                       | ✓                        | ✓                            | ✓                        |
| Lucciole Pendant   | ✓             | ✓                       | ✓                           |                                 | ✓                 | ✓                  | ✓                   | ✓                       | ✓                        | ✓                            | ✓                        |

# Installation Components

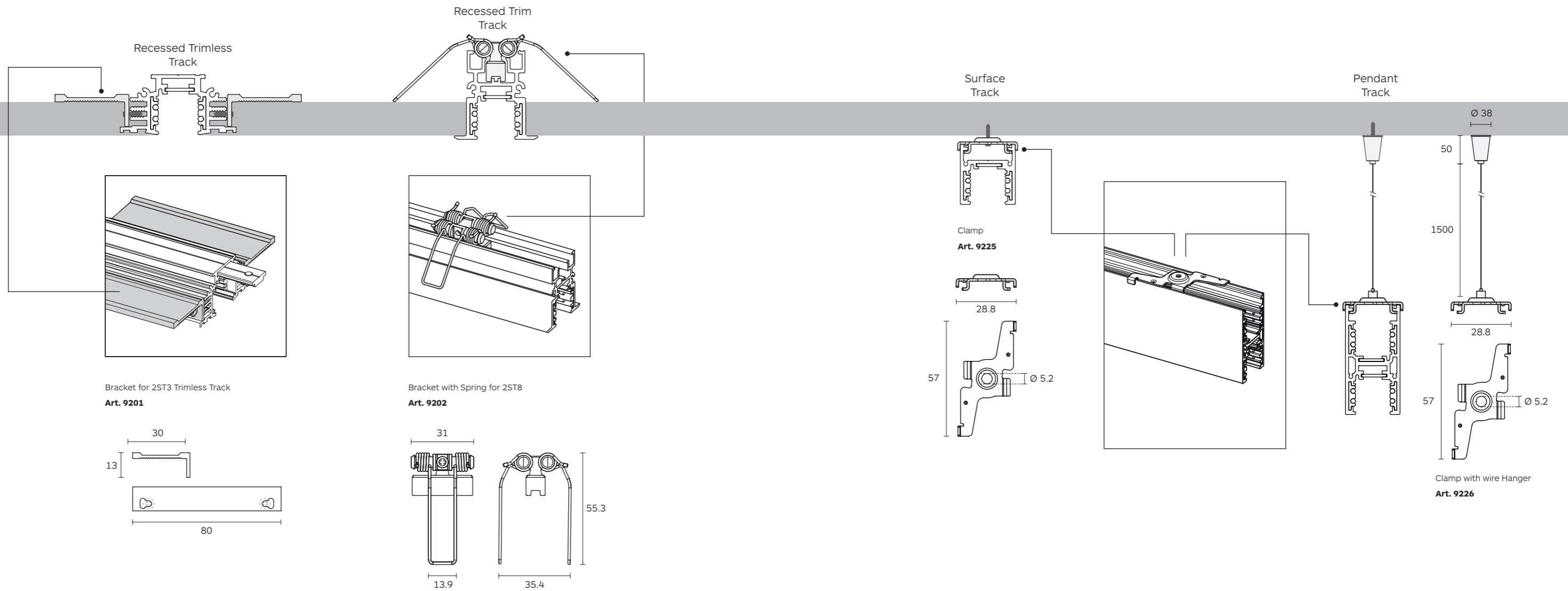

## EVO 48V Track

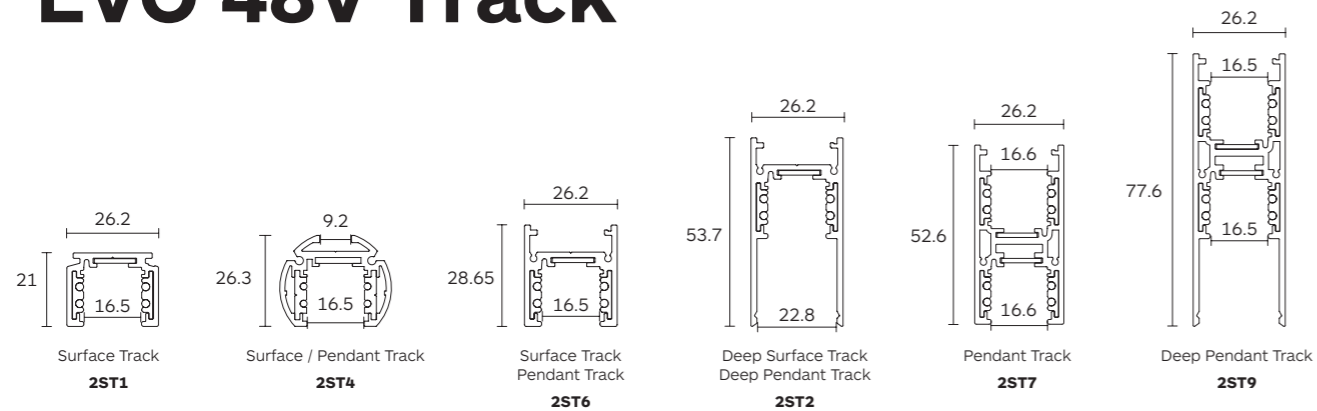

## EVO 48V Track

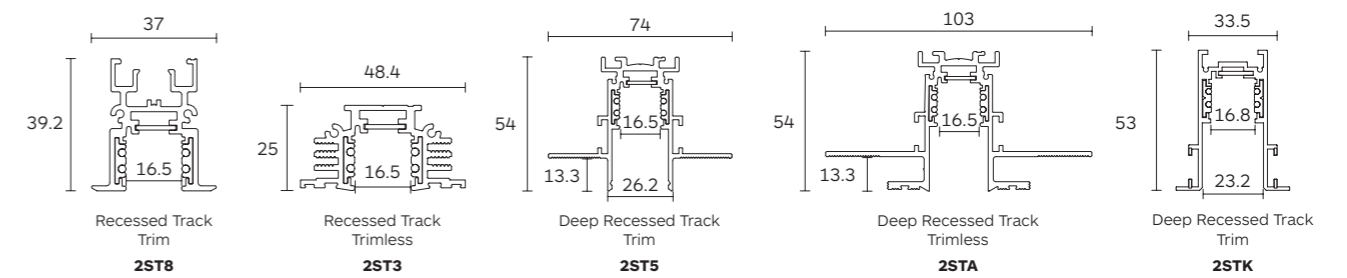

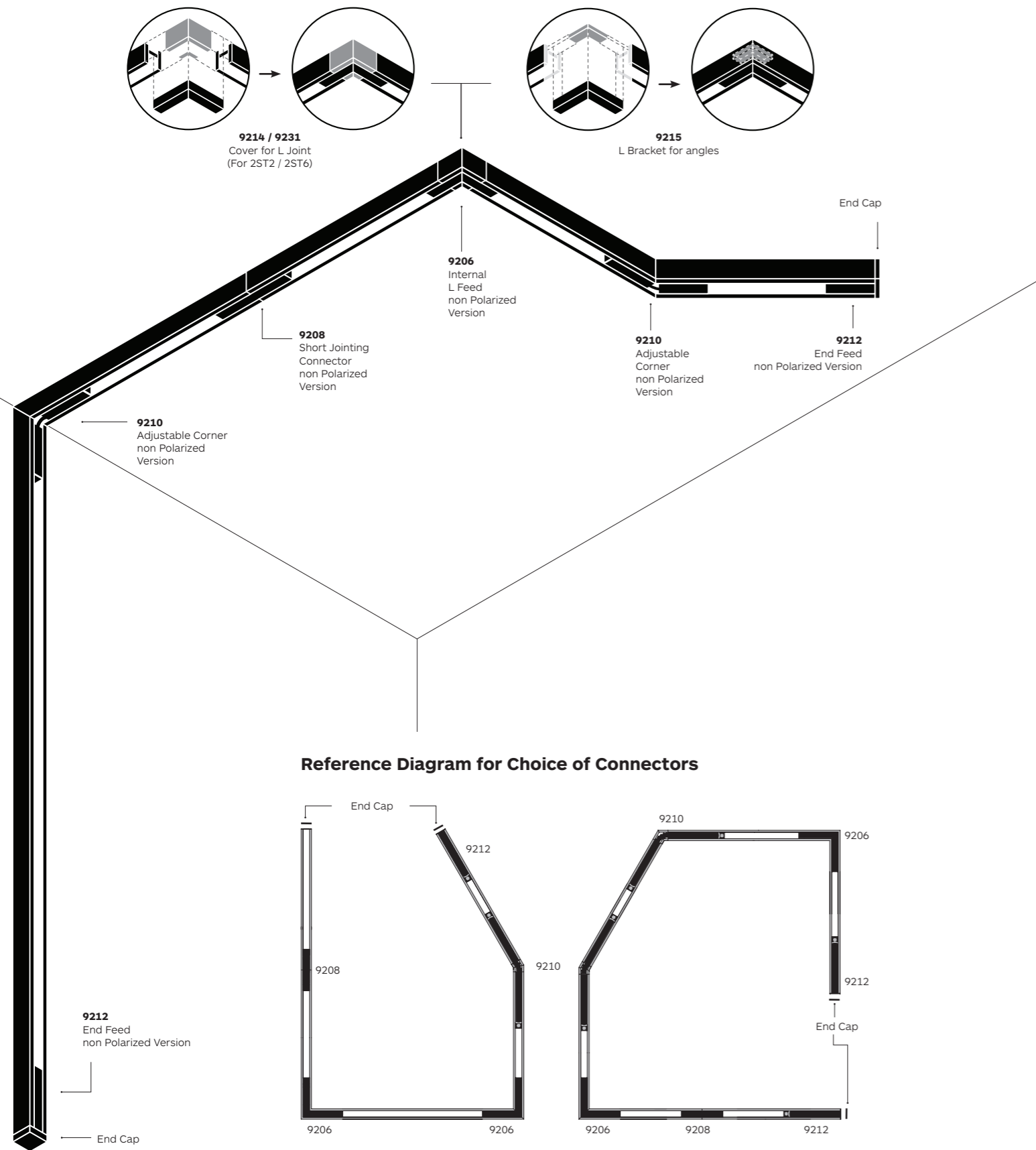







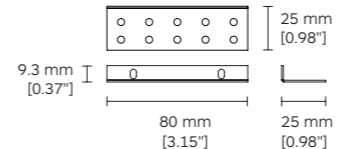

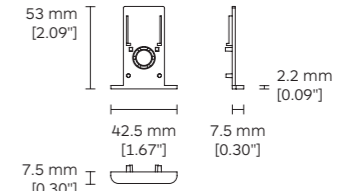

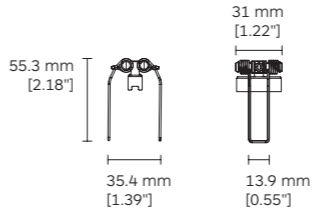

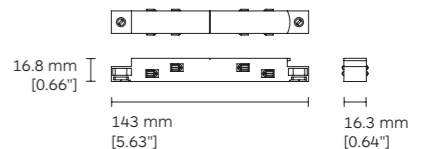

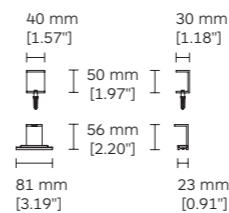

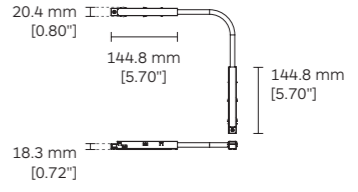

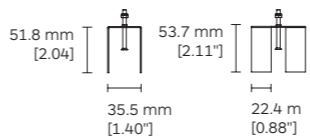

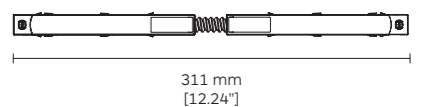

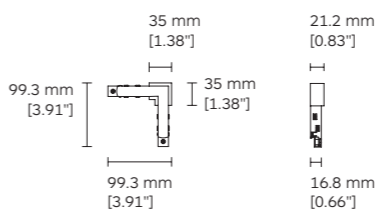
# Accessories

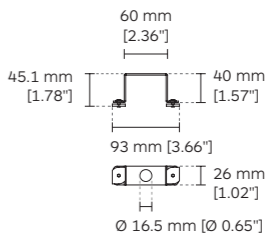
10 - Black

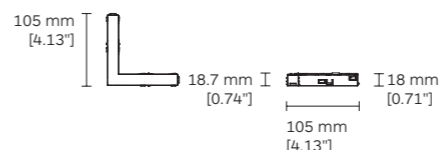
11 - White

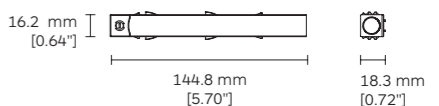
|  |  |
|--|--|
| <p><b>9201</b> Trimless Bracket (For 2ST3)</p>    | <p><b>9207</b> End Cap (For 2STK)</p>    |
| <p><b>9202</b> Bracket with spring (For 2ST8)</p>    | <p><b>9208</b> Short jointing connector non polarized version</p>     |
| <p><b>9203</b> Track suspension rod accessories (For 2ST2, 2ST6, 2ST7, 2ST8, 2ST9 &amp; 2STK)</p>   | <p><b>9209</b> Flex Corner in Polarized with Cable</p>     |
| <p><b>9204</b> Mounting Bracket (For 2STK)</p>     | <p><b>9210</b> Adjustable corner non polarized version</p>     |
| <p><b>9205</b> L feed with shell (For 2ST1)</p>    | <p><b>9211</b> U Bracket (For 2ST2, 2ST6, 2ST7 &amp; 2ST9)</p>   |
| <p><b>9206</b> Internal L feed non polarized version</p>    | <p><b>9212</b> End Feed non Polarized Version</p>     |

# Accessories

10 - Black

11 - White

**9214** Cover for L Joint (For 2ST2)

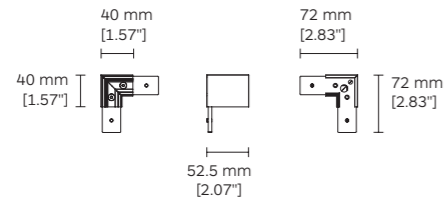

**9220** End Cap (For 2ST3)

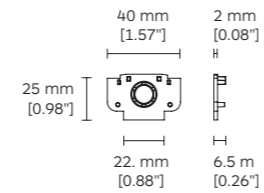

**9221** End Cap (For 2ST6)

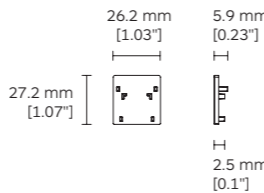

**9222** End Cap with hole (For 2ST6)

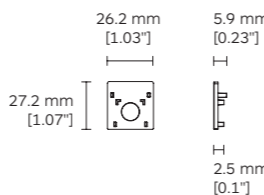

**9223** End Cap (For 2ST8)

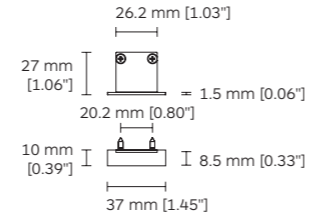

**9224** End Cap (For 2ST9)

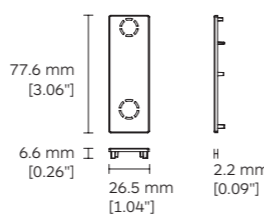

**9225** Clamp (For 2ST2 & 2ST6)

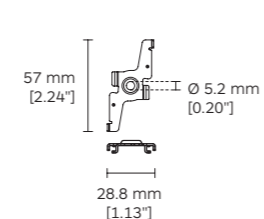

**9215** L Bracket for angles (For 2ST2, 2ST6)

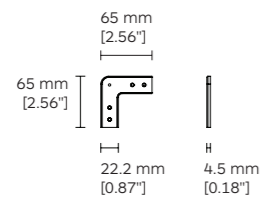

**9216** End Cap (For 2ST1)

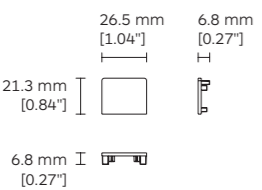

**9217** End Cap with Hole (For 2ST1)

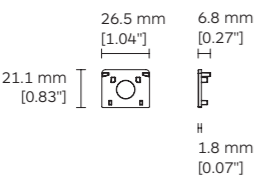

**9218** End Cap (For 2ST2)

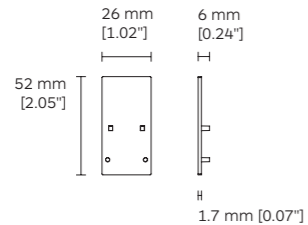

**9219** End Cap with hole (For 2ST2)

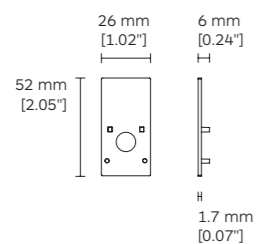

# Accessories

10 - Black

11 - White



**9226** Clamp with wire hanger (For 2ST2, 2ST6, 2ST7 & 2ST9)

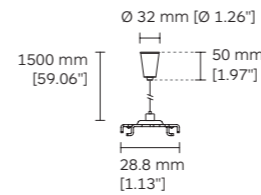

**9227** Reinforcing bracket for jointing connector (For 2ST3, 2ST4, 2ST5, 2ST8 & 2STA)

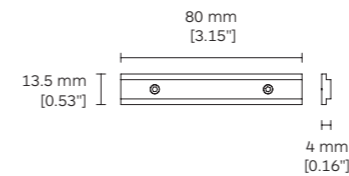

**9230** End Cap (For 2ST7)

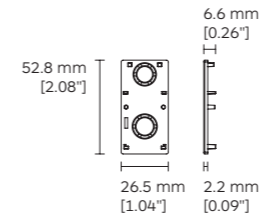

**9231** Cover for L joint (For 2ST6)

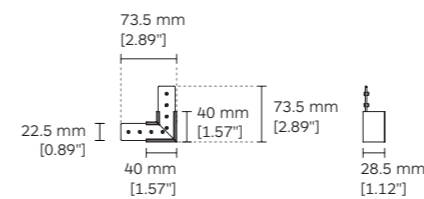

**9234** Bracket for jointing connector (For 2ST2, 2ST6 & 2ST8)

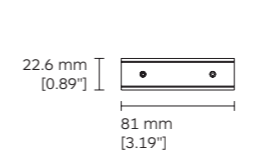

**9249** T Jointing connector non polarized version

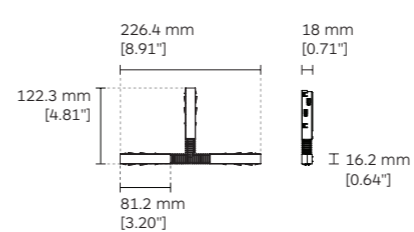

**9250** T type joint cover (For 2ST2)

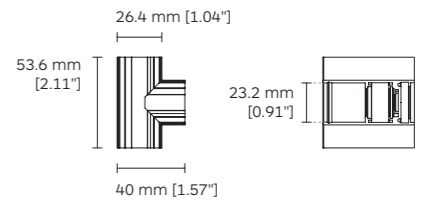

**9251** Cuttable lengths pendant rod (For 2ST3, 2ST6, 2ST7 & 2ST9)

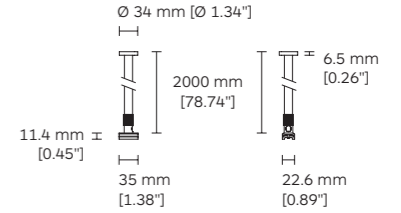

**9252** Straight connector with pendant wire (For 2ST2, 2ST6, 2ST7 & 2ST9)

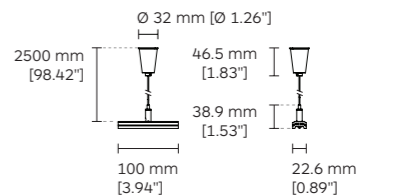

**9253** L Joint cover with pendant wire (For 2ST2)

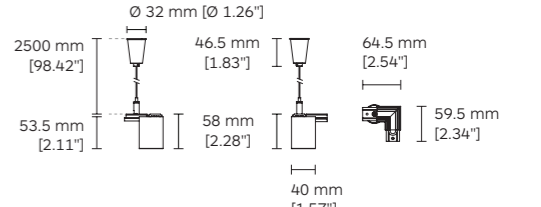

**9254** T Joint cover with pendant wire (For 2ST2)

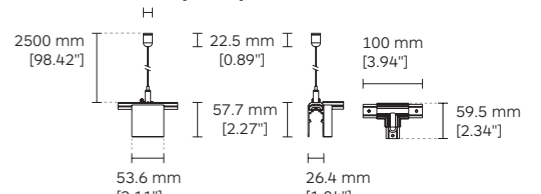

**9255** T Type Joint Cover (For 2ST1)

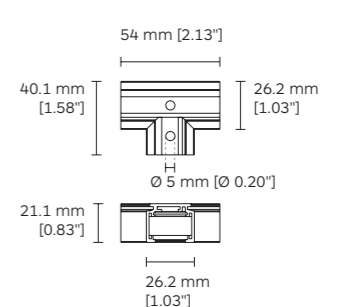

# Accessories

10 - Black

11 - White

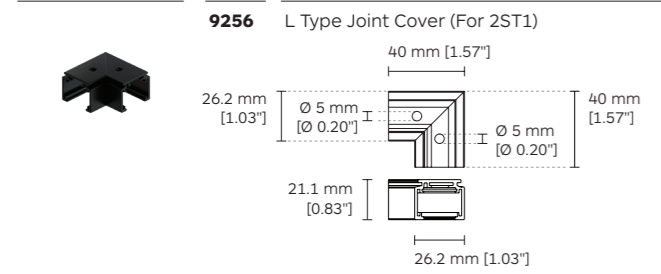

9256 L Type Joint Cover (For 2ST1)

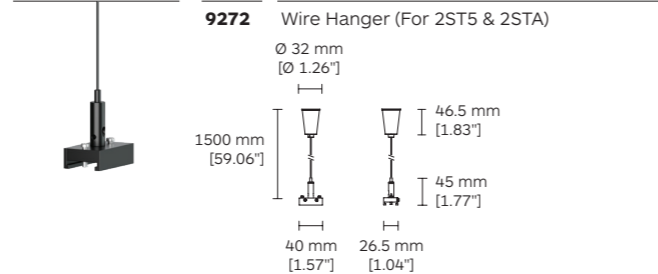

9272 Wire Hanger (For 2ST5 &amp; 2STA)

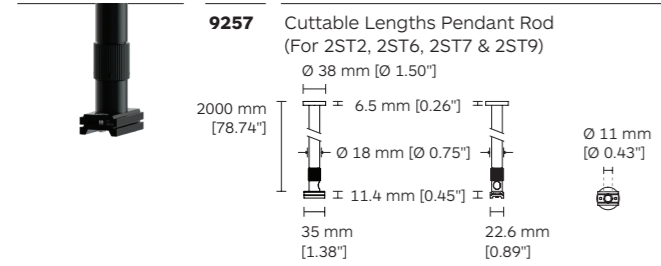

9257 Cuttable Lengths Pendant Rod (For 2ST2, 2ST6, 2ST7 &amp; 2ST9)

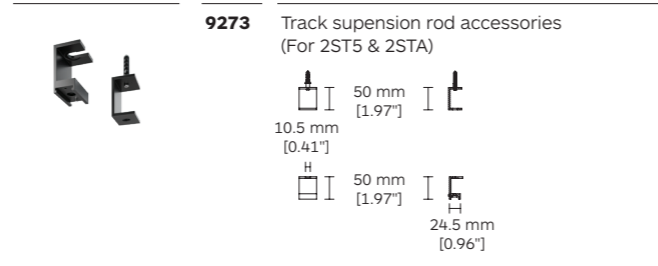

9273 Track suspension rod accessories (For 2ST5 &amp; 2STA)

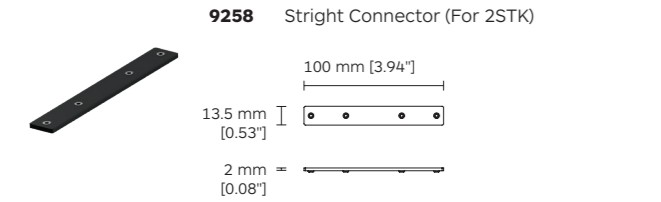

9258 Straight Connector (For 2STK)

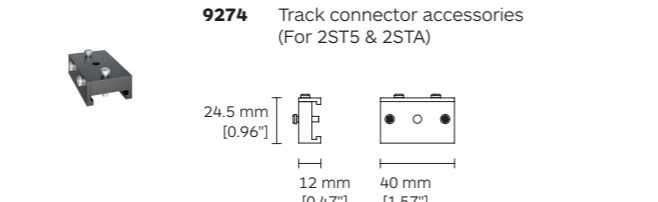

9274 Track connector accessories (For 2ST5 &amp; 2STA)

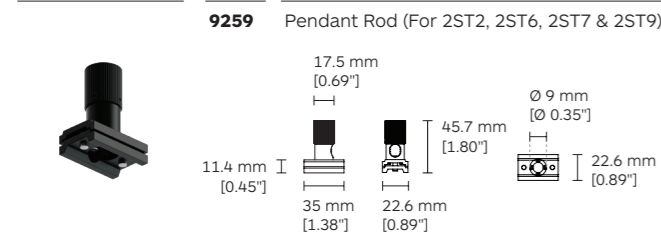

9259 Pendant Rod (For 2ST2, 2ST6, 2ST7 &amp; 2ST9)

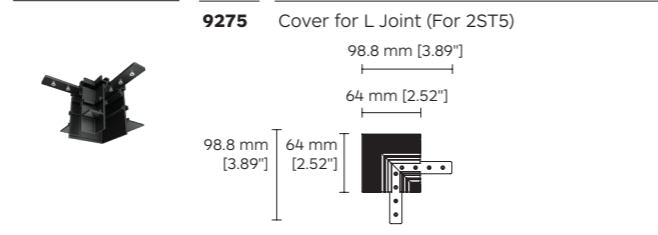

9275 Cover for L Joint (For 2ST5)

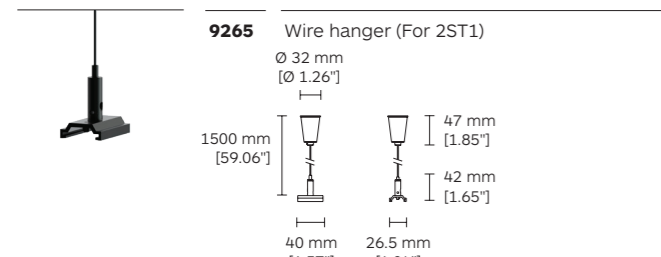

9265 Wire hanger (For 2ST1)

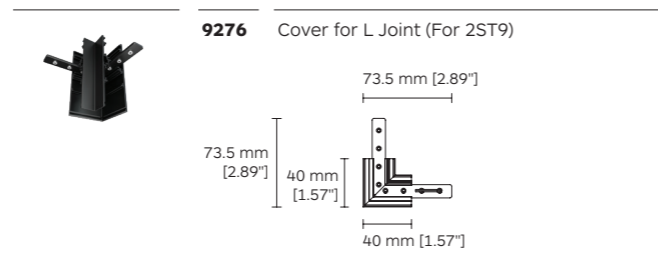

9276 Cover for L Joint (For 2ST9)

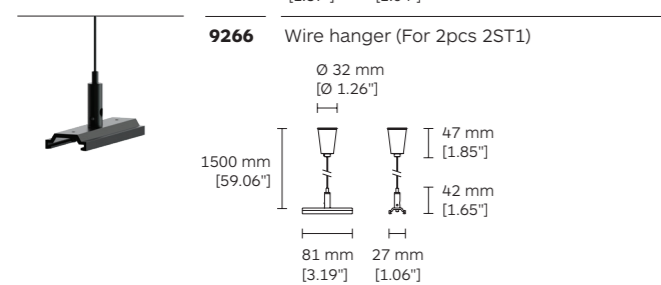

9266 Wire hanger (For 2pcs 2ST1)

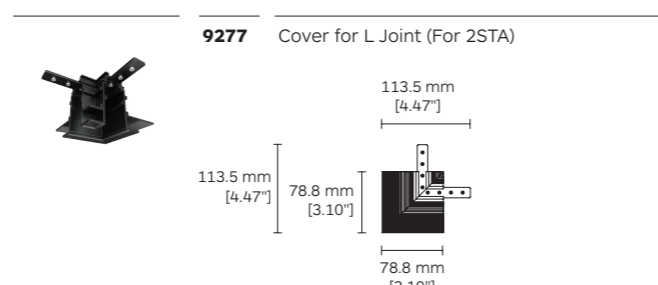

9277 Cover for L Joint (For 2STA)

# Accessories

10 - Black

11 - White

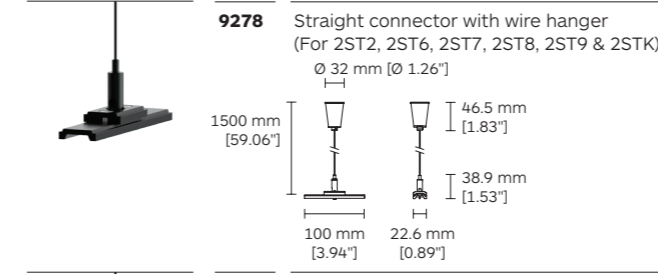

9278 Straight connector with wire hanger (For 2ST2, 2ST6, 2ST7, 2ST8, 2ST9 &amp; 2STK)

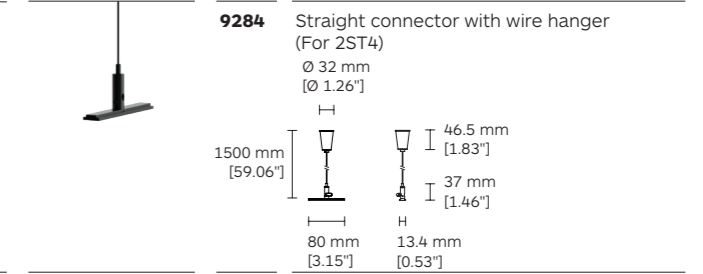

9284 Straight connector with wire hanger (For 2ST4)

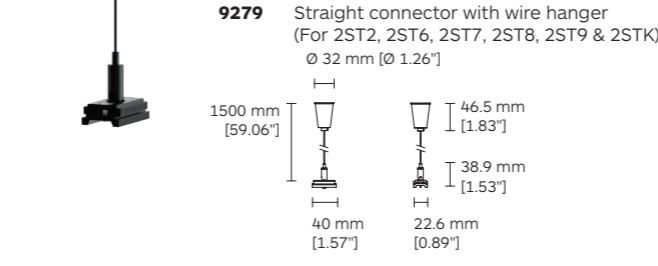

9279 Straight connector with wire hanger (For 2ST2, 2ST6, 2ST7, 2ST8, 2ST9 &amp; 2STK)

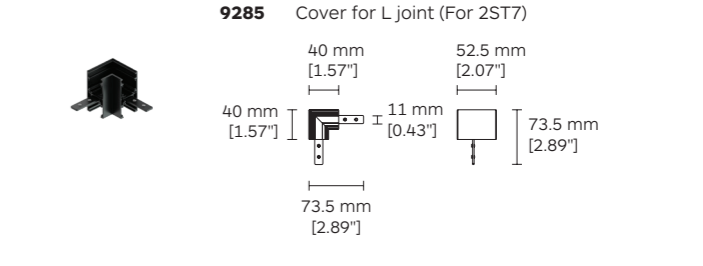

9285 Cover for L joint (For 2ST7)

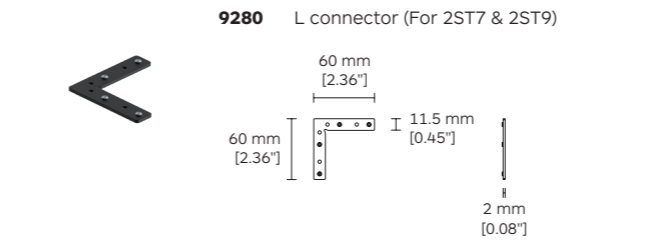

9280 L connector (For 2ST7 &amp; 2ST9)

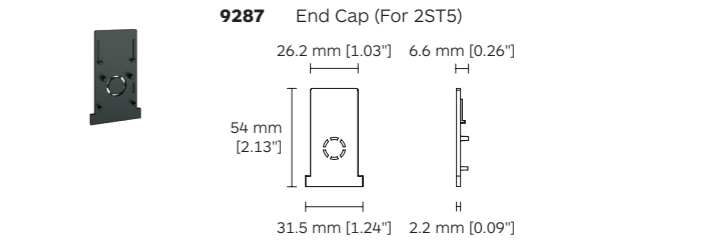

9287 End Cap (For 2ST5)

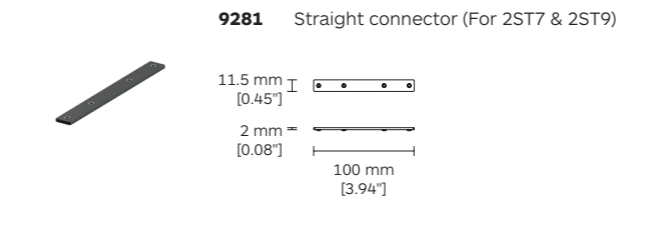

9281 Straight connector (For 2ST7 &amp; 2ST9)

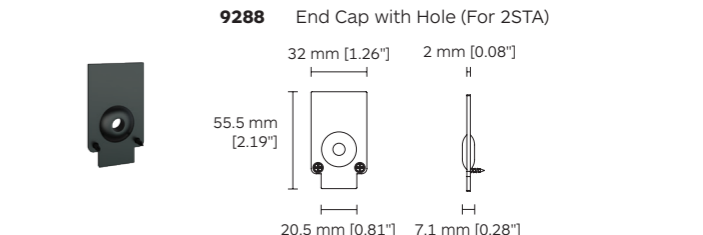

9288 End Cap with Hole (For 2STA)

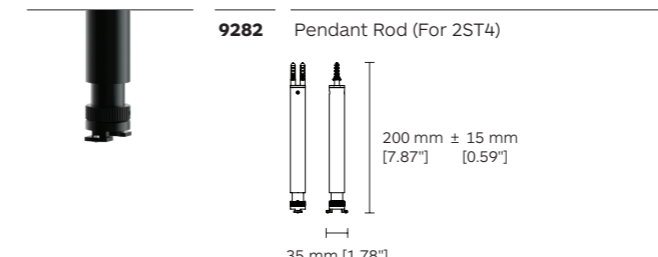

9282 Pendant Rod (For 2ST4)

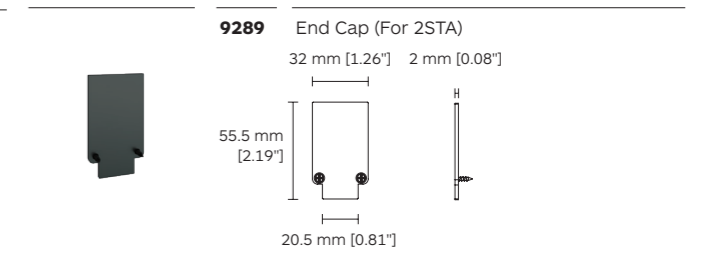

9289 End Cap (For 2STA)

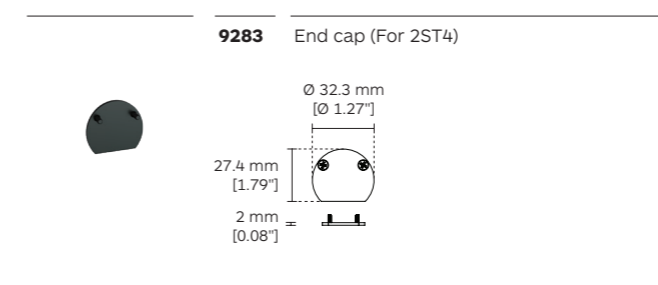

9283 End cap (For 2ST4)

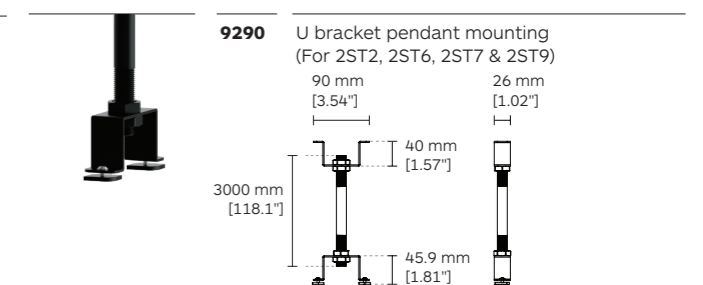

9290 U bracket pendant mounting (For 2ST2, 2ST6, 2ST7 &amp; 2ST9)

# Accessories

10 - Black

11 - White

**9291** Short End Feed Non Polarized

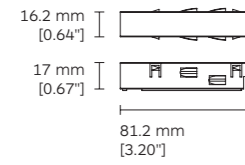

**2G45W** Wide width cover  
(For 2ST1, 2ST3, 2ST6, 2ST7 & 2ST8)

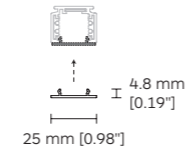

**9292** Short Jointing Connector Non Polarized

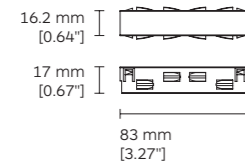

**2G54** L-bracket (For 2ST3, 2ST5, 2ST8 & 2STA)

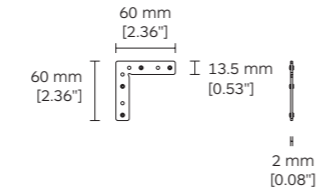

**2G45N** Narrow width cover

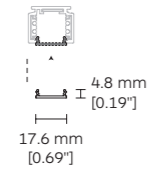

**2H19** M8 Rod mounting bracket & Straight connector  
(For 2ST2, 2ST6, 2ST7 & 2ST9)

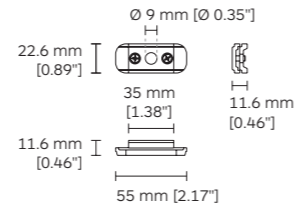

**2G45M** Medium width cover  
(For 2ST2, 2ST5, 2ST9, 2STA & 2STK)

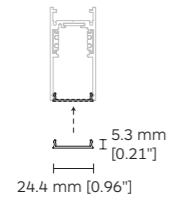
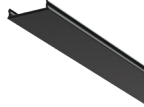

**2H20** Straight connector  
(For 2ST2, 2ST6, 2ST7 & 2ST9)

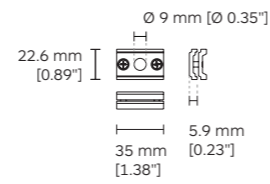

# Driver Options

# Power Supply & Control Options

## Power Supply



220-240VAC input, 48VDC output 75w power supply for EVO 48V LV track  
 220-240VAC input, 48VDC output 150w power supply for EVO 48V LV track  
 220-240VAC input, 48VDC output 100W power supply for EVO 48V LV track  
 220-240VAC input, 48VDC output 200W power supply for EVO 48V LV track  
 220-240VAC input, 48VDC output 100W power supply for EVO 48V LV track deep recessed

| Code | 2E28           | 2E29           | 2F07     | 2F08     | 2F09     |
|------|----------------|----------------|----------|----------|----------|
| Size | 100 x 235 x 31 | 100 x 235 x 31 | 23 x 225 | 23 x 315 | 38 x 225 |

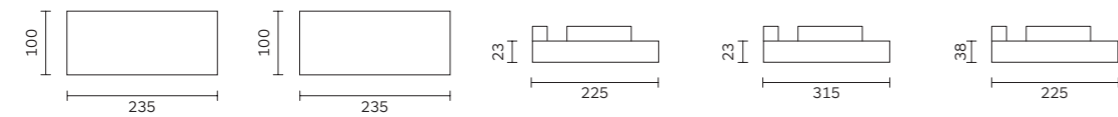

## Universal DALI

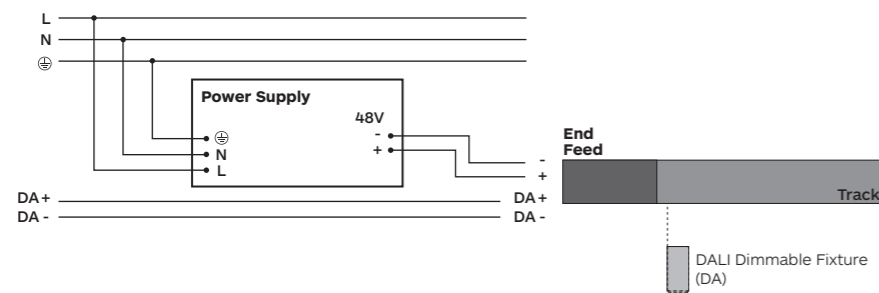

## Bluetooth wireless Control

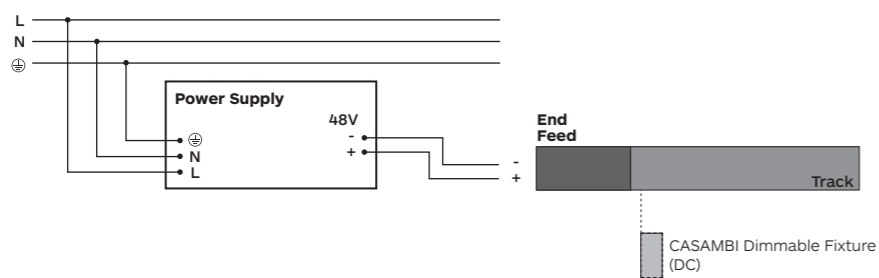

## Fixed Output

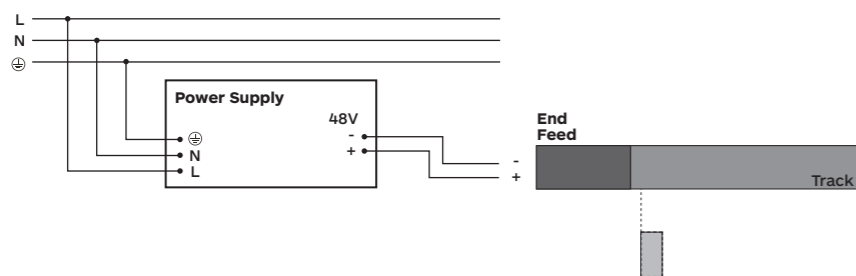

# Drop Voltage Table

| Power Supply (W) | A Distance power supply/feed unit (2x1.5mm <sup>2</sup> ) |     |              |              |
|------------------|---|-----|--------------|--------------|
|                  | 5m  | 10m | 20m          | 30m          |
|                  |   |     |              |              |
|                  | B Track Length with $\Delta v \leq 5.5\%$ (m)             |     |              |              |
| (m)              | (m)   | (m) | (m)          | (m)          |
| 60               | 50  | 50  | 50           | 50           |
| 100              | 50  | 50  | 40           | 25           |
| 150              | 50  | 40  | 20           | Not admitted |
| 200              | 40  | 30  | Not admitted | Not admitted |
| 250              | 35  | 20  | Not admitted | Not admitted |

Information refers to a load equivalent to the power supplied and equally distributed on the relevant length in the table.

## Remote Power Supply

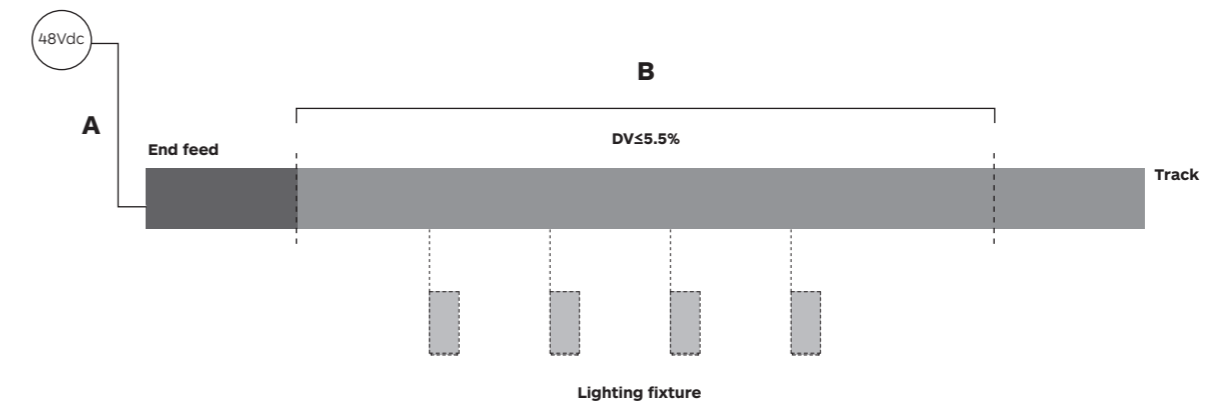

**Symbols & Icons**  
**Code system**  
**Global presence**

## Symbols & Icons

CE Mark - Product complies with CE Standard.



CSA Mark - Product complies with USA & Canada Standard.



### Other third party product approvals

Our products include electrical and electronic components that carry other world wide Test House approvals such as those shown:



### CLASS I

Luminaires of insulation Class I - with earth connector.



### CLASS II

Luminaires of insulation Class II - With safety isolation, this means the tension conduction element are protected by additional isolation. The isolation of an earth wire it is not necessary and the connection to it is not allowed.



48V input Class III



Zoom



Passes the 850° glow wire test in accordance with IEC 695-2-1.



Passes the 960° glow wire test in accordance with IEC 695-2-1.



Dim2Warm



Tunable White



CASAMBI



Recyclable



## IP\_\_ Degree of Ingress Protection IP\_\_

| 1st Number | Protection Against Dust and Solid Objects | 2nd Number | Protection Against Moisture and Liquids           |
|------------|---|------------|---|
| 0          | No-Protection                             | 0          | No-Protection                                     |
| 1          | Protection against solid objects >50 mm   | 1          | Protection against dripping water                 |
| 2          | Protection against solid objects >12 mm   | 2          | Protection against dripping water tilted > 15 deg |
| 3          | Protection against solid objects >2.5 mm  | 3          | Protection against spraying water > 30 deg        |
| 4          | Protection against solid objects >1 mm    | 4          | Protection against spraying water                 |
| 5          | Dust - protected                          | 5          | Protection against water jet                      |
| 6          | Dust - tight                              | 6          | Protection against waves                          |
|            |   | 7          | Protection against the effects of immersion       |
|            |   | 8          | Protection against submersion                     |

## Body Color

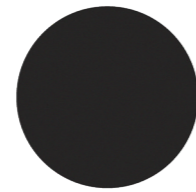

**10** Black (RAL 9004)



**65** Embossed matt black (RAL 9017)

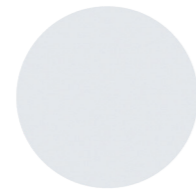

**11** White (RAL 9003)



**54** Embossed matt white (RAL 9016)



**\*17** Black (RAL 9004) / White (RAL 9003 (B&W))

## Code System

Code ordering example: **9 6 6 4 J C 0 1 - 9 7 3 0 2 4 D 0 5 4**

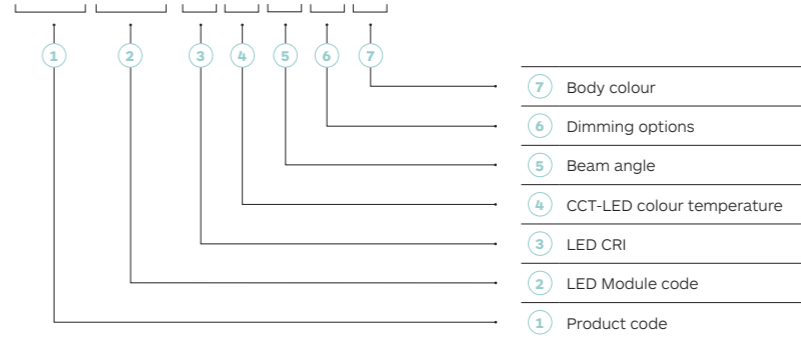

| LED CRI            | CCT-LED Colour temperature    | Dimming Options      | Body Colour  |
|--------------------|-------------------------------|----------------------|--|
| <b>90</b> CRI > 90 | <b>27</b> Warm White 2700K    | <b>D0</b> No dimming | <b>10</b> Black (RAL 9004)                           |
| <b>93</b> CRI > 93 | <b>30</b> Warm White 3000K    | <b>DA</b> Dali Dim   | <b>11</b> White (RAL 9003)                           |
| <b>97</b> CRI > 97 | <b>35</b> Warm White 3500K    | <b>DC</b> CASAMBI    | <b>*17</b> Black (RAL 9004) / White (RAL 9003 (B&W)) |
| <b>98</b> CRI > 98 | <b>40</b> Neutral White 4000K | <b>D1</b> 0-10V Dim  | <b>54</b> Embossed matt white (RAL 9016)             |
|                    |                               |                      | <b>65</b> Embossed matt black (RAL 9017)             |

**Notes:**  
**\*17:** white light body with black integrated louvre. For black body with white integrated louvre consult us.

## How to order

|           | Product Code | LED Module Code | LED Power | Nominal Lumen | Beam Angle (BA°)       |
|-----------|--------------|-----------------|-----------|---------------|------------------------|
| TicTok 35 | <b>96B3</b>  | <b>E013</b>     | 5W        | 620 lm        | <b>08°</b>             |
| TicTok 45 | <b>9662</b>  | <b>JC02</b>     | 9W        | 975 lm        | <b>18° / 26° / 38°</b> |
| TicTok 58 | <b>9664</b>  | <b>JC01</b>     | 14W       | 1590 lm       | <b>24° / 34°</b>       |

| Code | Description                | Value       |
|------|----------------------------|-------------|
| 1    | Product code               | <b>9664</b> |
| 2    | LED Module code            | <b>JC01</b> |
| 3    | LED CRI                    | <b>97</b>   |
| 4    | CCT-LED colour temperature | <b>30</b>   |
| 5    | Beam angle                 | <b>24</b>   |
| 6    | Dimming options            | <b>D0</b>   |
| 7    | Body colour                | <b>54</b>   |

| Code | Description         | Value |
|------|---------------------|-------|
| 10   | Black               |       |
| 65   | Embossed matt black |       |
| 11   | White               |       |
| 54   | Embossed matt white |       |

| Code | Description | Value |
|------|-------------|-------|
| D0   | No Dim      |       |
| DA   | Dali Dim    |       |
| DC   | CASAMBI     |       |
| D1   | 0-10V Dim   |       |

| Code | Description | Value |
|------|-------------|-------|
| 27   | 2700K       |       |
| 30   | 3000K       |       |
| 35   | 3500K       |       |
| 40   | 4000K       |       |

# Global presence

Celebrating over 50 years of vision, dedication and innovation, formalighting's versatile and high-quality product offerings extends internationally via our headquarters in Hong Kong, London, Milan and Shanghai.

Our well chosen and selected partners as well as our affiliated international offices broaden our global presence further in markets such as USA, Australia, Japan, South East Asia, India and the Middle East.

Through our commitment to growth and investment within formalighting's professional team, infrastructure and product ranges, we are able to provide increasing service to our global retail and hospitality clients as well as lighting designers and specifiers strengthening our position as a leading international supplier of innovative architectural lighting solutions and systems.

With over 50 years' experience in designing and manufacturing architectural lighting, formalighting's comprehensive portfolio offers a competitive range of European designed and expertly engineered products that carry CB, CE, CCC and UL certifications.

Furthermore formalighting's latest award-winning motorized range of track, pendant, and recessed fixtures, featuring remote-controlled adjustable pan and tilt, dim, dim to warm, tuneable white and beam shaping lens, are available worldwide incorporating the latest, most advanced lighting technologies.

## MILAN

### EUROPE HEADQUARTERS

Tel ( +39 ) 02 9354 0300

Fax ( +39 ) 02 9343 5117

E- mail info-europe@formalighting.com

## HONG KONG

### ASIA HEADQUARTERS

Tel ( +852 ) 2516 6500

Fax ( +852 ) 2516 6525

E- mail info-asia@formalighting.com

## NEW YORK

### LOCAL SALES OFFICE

E- mail info-us@formalighting.com

## SHANGHAI

### LOCAL SALES OFFICE

E- mail info-china@formalighting.com

## LONDON

### LOCAL SALES OFFICE

E- mail info-uk@formalighting.com

## AUSTRALIA

### LOCAL SALES OFFICE

Tel ( +61 ) 488 567 388

E- mail info-australia@formalighting.com

## INDIA

### LOCAL SALES OFFICE

Tel ( +91 ) 9686351257

E- mail info-india@formalighting.com

formalighting is constantly developing and improving its products therefore all information, drawings illustrations, specifications, photometric values in this catalogue are indicatives and shall not form part of any commitment by our company that reserves the right to change specifications without prior notification or public announcement.

Technical information on the installation-instruction has precedence over the information in the catalogue.

Our general terms and conditions shall apply notwithstanding any stipulation on the contrary to all the orders and agreement with formalighting. You can obtain a copy of these conditions on demand.

Publication date: May 2026  
©Copyright formalighting

With thanks to all contributors for the realization of this catalogue

Designed by formalighting's Graphic Design Department

No part of this catalogue may be copied without written authorization of formalighting

[www.formalighting.com](http://www.formalighting.com)

**formalighting**

# formalighting

MILAN

-

LONDON

-

USA

-

HONG KONG

-

SHANGHAI

-

INDIA