

The background features a large teal shape on the left and top, a yellow square in the center, and a grey diamond shape below it. A black shape is visible on the far left edge.

formalighting

# **Zero Framing Projector Series**

**2026**

# Zero Framing Projector Series

# Zero Framing Projector



Collected Light Exhibition. Milan 2023  
Cascina Cuccagna - formalighting's Demo Room featuring the high performance  
Zero Framing Projector 85 and Zero Framing Projector 38.

The hero of formalighting's track-mounted range for museums and galleries, for the professional illumination of objects, with high precision optics and sharp outlines.

An advanced multifunctional projector with built-in bidirectional zooming lens with sharpness adjustability and lens rotation. Also compatible with Gobo Insertion.

Available for EURO Track, Low Voltage Track, Semi-Recessed, and Surface Mounted versions.

# Zero Projector Lighting Effect

## Precision light contouring



## Image Projection

CCTs Options



## Custom Graphics Projection



# Contour Spotlights

Create perfect displays of art  
in museums and galleries

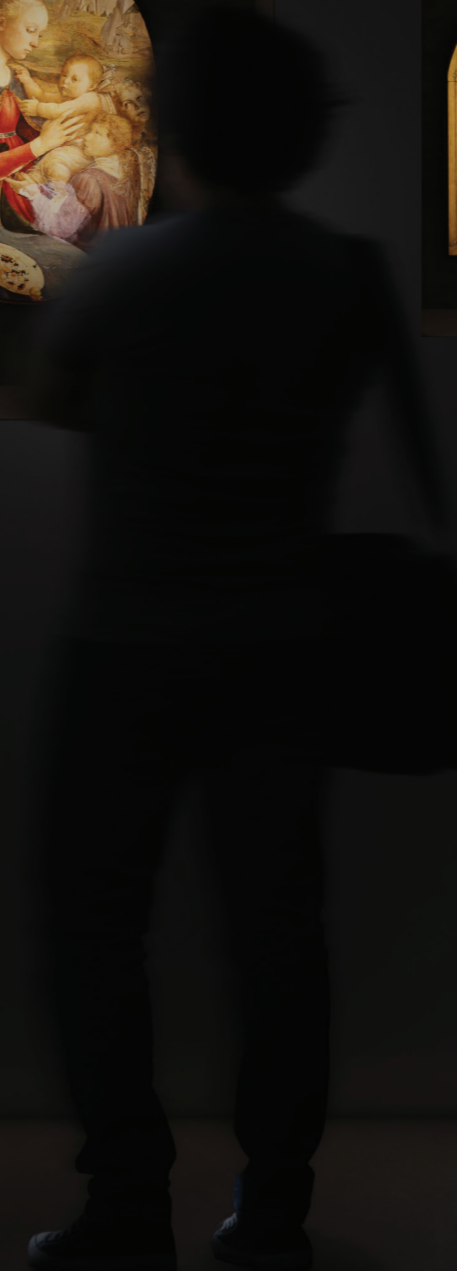
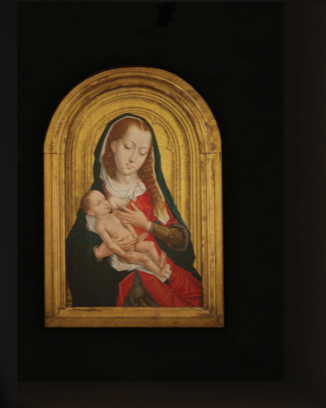
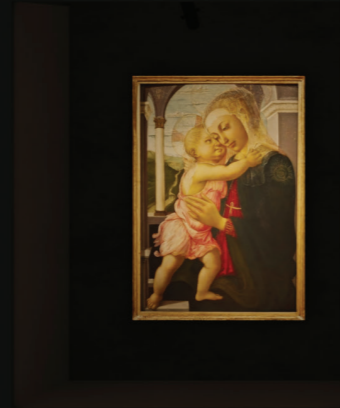

Our Zero Framing Projectors allow you to create beautiful lighting effects for your artwork.

Formalighting has created a solution with its contour spotlights. These allow curators and lighting designers to cast precise beams of light that highlight exhibits in galleries and museums while leaving the background in darkness for a magical effect. Unlike traditional projectors, which are limited to a single lighting style, our spotlights offer flexibility. You can easily switch from a framing light to a spotlight with a round beam without any tools.

# Framing Light Distribution

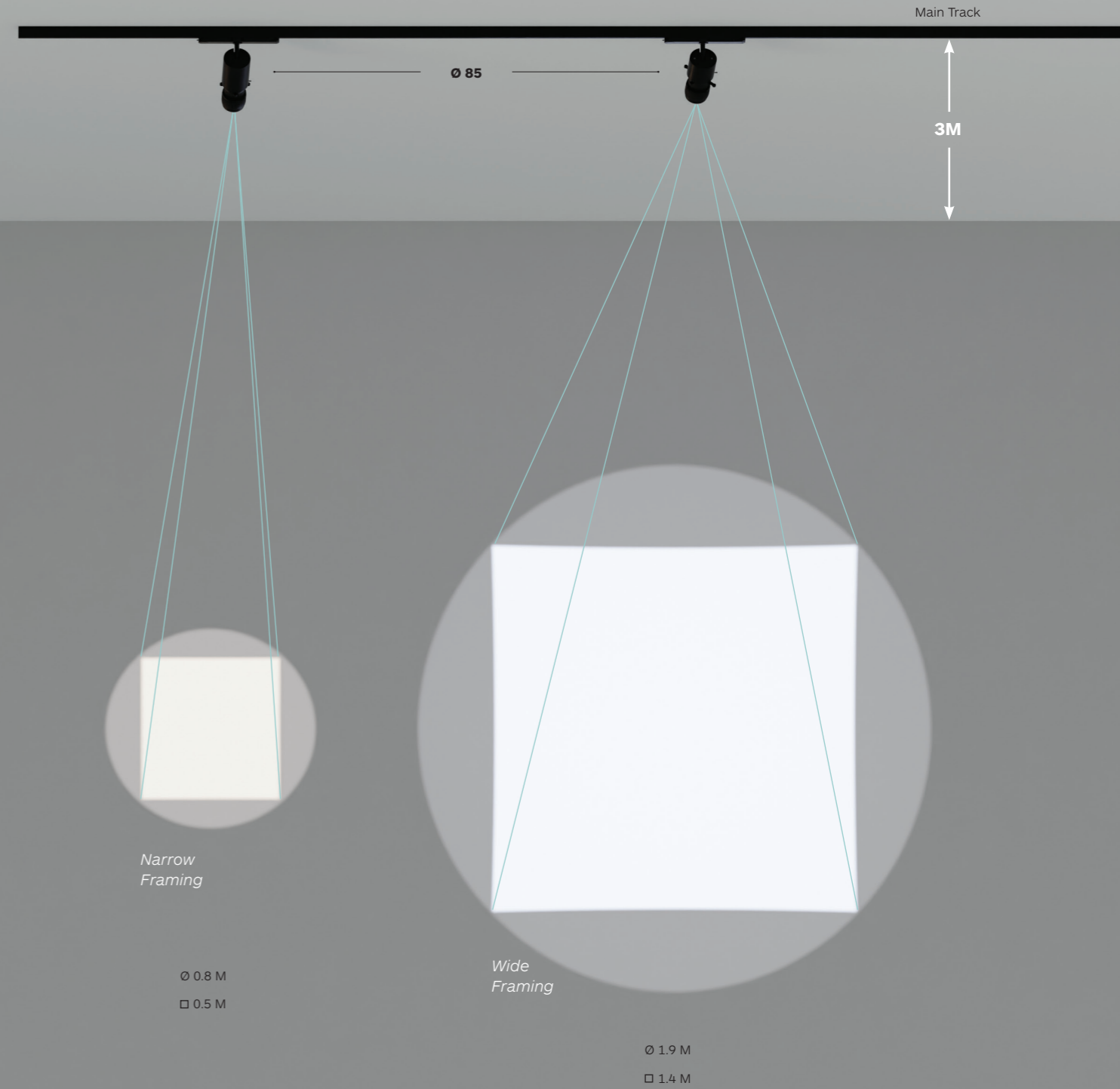
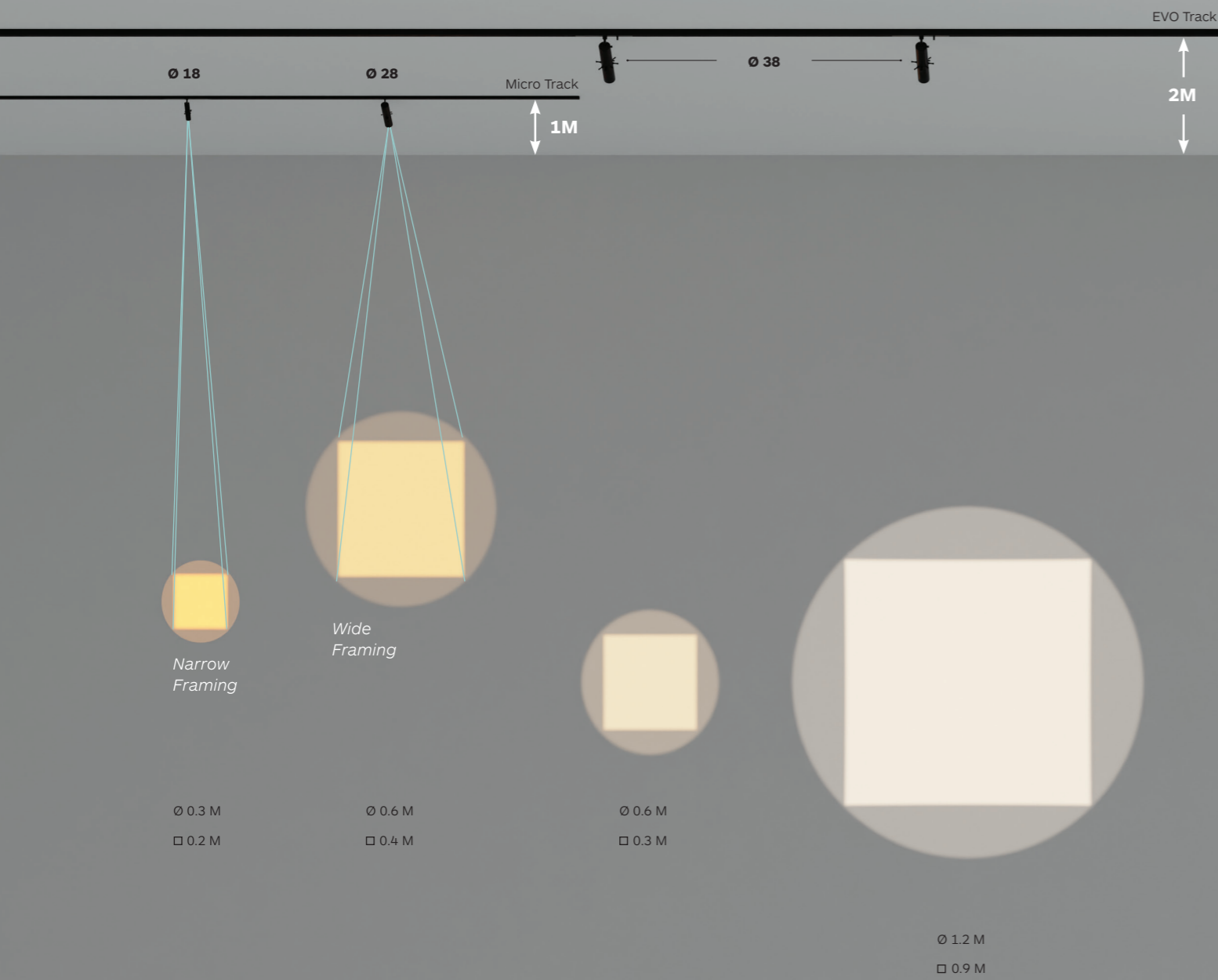

# Projection Spacing

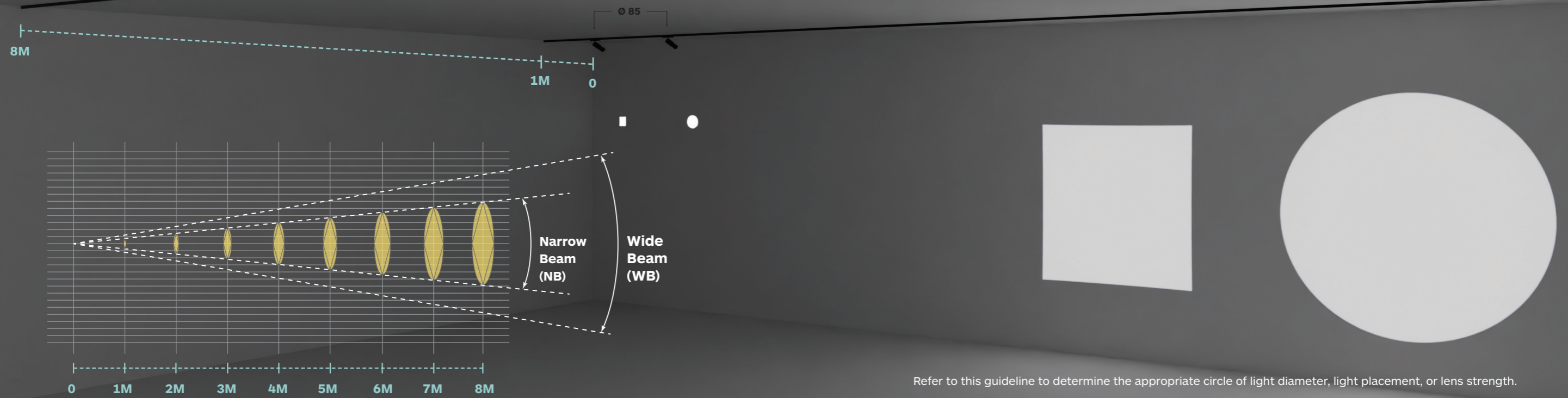

Refer to this guideline to determine the appropriate circle of light diameter, light placement, or lens strength.

Zero Framing Projector 18 BS: Beam Shaping Beam Angle: 15° - 33°	Zero Framing Projector 28 BS: Beam Shaping Beam Angle: 12° - 32°	Zero Framing Projector 38 BS: Beam Shaping Beam Angle: 14° - 35°		Projection Distance (M)								
				1M	2M	3M	4M	5M	6M	7M	8M	
	<b>NB</b> : 15°	●	Circular Spot Diameter (M)	Ø 0.3	Ø 0.6	Ø 0.9	Ø 1.2	-	-	-	-	
	<b>WB</b> : 33°	●		Ø 0.6	Ø 1.3	Ø 1.8	Ø 2.5	-	-	-	-	
	<b>NB</b> : 15°	■	Square Spot Side Length (M)	L 0.2	L 0.3	L 0.6	L 0.8	-	-	-	-	
	<b>WB</b> : 33°	■		L 0.4	L 0.9	L 1.3	L 1.7	-	-	-	-	
	<b>NB</b> : 12°	●	Circular Spot Diameter (M)	Ø 0.3	Ø 0.5	Ø 0.8	Ø 1.0	Ø 1.2	Ø 1.5	Ø 1.7	-	
	<b>WB</b> : 32°	●		Ø 0.6	Ø 1.3	Ø 1.9	Ø 2.4	Ø 3.2	Ø 3.8	Ø 4.5	-	
	<b>NB</b> : 12°	■	Square Spot Side Length (M)	L 0.2	L 0.3	L 0.5	L 0.7	L 0.9	L 1.0	L 1.2	-	
	<b>WB</b> : 32°	■		L 0.4	L 0.9	L 1.4	L 1.8	L 2.3	L 2.7	L 3.2	-	
	<b>NB</b> : 14°	●	Circular Spot Diameter (M)	Ø 0.3	Ø 0.6	Ø 0.9	Ø 1.2	Ø 1.5	Ø 1.8	Ø 2.2	Ø 2.5	
	<b>WB</b> : 35°	●		Ø 0.6	Ø 1.2	Ø 1.8	Ø 2.4	Ø 2.9	Ø 3.5	Ø 4.1	Ø 4.7	
	<b>NB</b> : 14°	■	Square Spot Side Length (M)	L 0.2	L 0.3	L 0.6	L 0.8	L 1.0	L 1.3	L 1.6	L 1.8	
	<b>WB</b> : 35°	■		L 0.4	L 0.9	L 1.3	L 1.6	L 2.1	L 2.5	L 2.9	L 3.3	

Zero Framing Projector 85		Projection Distance (M)									
Main Track: 1462 Surface: 6640	Main Track: 1463 Surface: 6641			1M	2M	3M	4M	5M	6M	7M	8M
				BS: Beam Shaping	<b>NB</b> : 13°	●	Circular Spot Diameter (M)	Ø 0.3	Ø 0.5	Ø 0.8	Ø 1.0
Beam Angle: 13° - 23°	<b>WB</b> : 23°	●		Ø 0.4	Ø 0.9	Ø 1.3	Ø 1.7	Ø 2.2	Ø 2.6	Ø 3.0	Ø 3.4
	<b>NB</b> : 13°	■	Square Spot Side Length (M)	L 0.2	L 0.4	L 0.5	L 0.7	L 0.9	L 1.1	L 1.3	L 1.4
	<b>WB</b> : 23°	■		L 0.3	L 0.6	L 0.9	L 1.2	L 1.5	L 1.8	L 2.1	L 2.4
BW: Beam Wide	<b>NB</b> : 23°	●	Circular Spot Diameter (M)	Ø 0.4	Ø 0.8	Ø 1.2	Ø 1.6	Ø 2.0	Ø 2.4	Ø 2.8	Ø 3.2
Beam Angle: 23° - 36°	<b>WB</b> : 36°	●		Ø 0.6	Ø 1.3	Ø 1.9	Ø 2.6	Ø 3.2	Ø 3.9	Ø 4.5	Ø 5.2
	<b>NB</b> : 23°	■	Square Spot Side Length (M)	L 0.3	L 0.6	L 0.8	L 1.1	L 1.4	L 1.7	L 2.0	L 2.3
	<b>WB</b> : 36°	■		L 0.5	L 0.9	L 1.4	L 1.8	L 2.3	L 2.8	L 3.2	L 3.7

# Optical Accessory Gobo Film

A zero-framing projector, a gobo, and a projection surface are all required for logo projection. The gobo is a little template film that displays a customized logo or other creative image.

The gobo film is inserted into the Zero Framing projector, and the picture emerges on the ideal surface. Choose the appropriate gobo for your design and projector to achieve a clear image at the correct size and brightness.



Gobo  
Film



**Gobo Film**  
available for 4 sizes

**1. Zero Framing Projector 85**



**2F29**

**2. Zero Framing Projector 38**



**2G24**

**3. Zero Framing Projector 28**



**2G92**

**4. Zero Framing Projector 18**



**2G91**

# PRODUCTS INDEX

## Recessed & Semi-Recessed



Ø 38  
P. 18



Ø 18  
Ø 28  
Ø 38  
P. 18

## Surface Mounted



Ø 18  
Ø 28  
Ø 38  
P. 28-30



Ø 85  
P. 28

## Main Voltage Track

Ø 38  
P. 20



Ø 85  
P. 20



Ø 85  
P. 20

36  
32

## EVO Track

DC  
48V

Ø 28  
Ø 38  
P. 22



Ø 38  
P. 22

21  
26.2

## Micro Track

DC  
48V

Ø 18  
Ø 28  
P. 24



## Mini Track

DC  
24V

Ø 28  
P. 26



Ø 18  
P. 26

110.2  
19

# Zero Framing Projector

Semi Recessed & Recessed

Advanced, multi-functional LED semi-recessed and recessed mounted projector. With a built-in bidirectional zooming lens with sharpness adjustability, and lens rotation.

Adjustable shutters to re-frame the beam to the desired size and shape. Compatible with Gobo insertion for logo. High-precision optics for sharp outlines and high degree of lighting uniformity.

For complete code ordering information, please see page 35.

**LED Sources:**

High Rendering:  
CRI: 97 | CCT: 2700K, 3000K, 3500K, 4000K.

**Accessories:**

- Gobo Film, see page 15 for details
- Contact us for custom-made logo projection lens.

- 10 - Black
- 11 - White



## Zero Framing Projector Semi-Recessed & Recessed



Ø 25mm  
[Ø 0.98"]



**RR72**

Ø 30mm  
[Ø 1.18"]



**RR73**

Ø 60mm  
[Ø 2.36"]



**RR56**

Ø 185mm  
[Ø 7.28"]



**RR71**

Ø 30mm  
[Ø 1.18"]

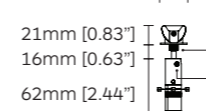

Ø 18mm  
[Ø 0.71"]

Ø 35mm  
[Ø 1.38"]

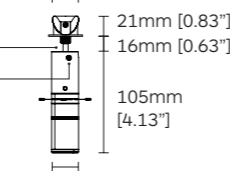

Ø 28mm  
[Ø 1.10"]

Ø 68mm  
[Ø 2.68"]

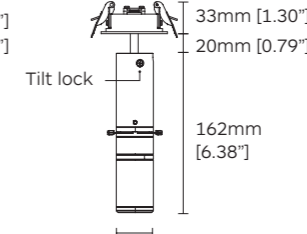

Ø 38mm  
[Ø 1.50"]

Ø 172mm  
[Ø 6.77"]

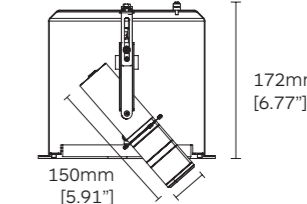

Ø 38mm [Ø 1.50"]

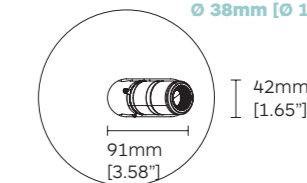

Ø 195mm [7.68"]

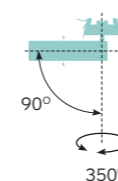
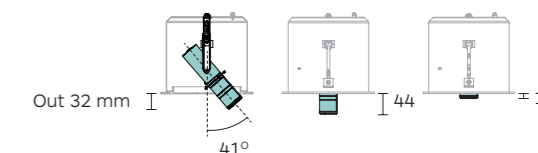

	Product Code	LED Source Code	LED Power	Nominal Lumen	Beam Angle	Dimming Options	CCT Options
<b>CRI &gt; 97</b> <b>3000K</b> <b>High Rendering</b>	Zero Framing Projector 18	<b>RR72</b> ○	<b>BC52</b>	2.4	205 lm	<b>BS</b> (15°-35°)	<b>D0</b> No Dim <b>27</b> 2700K
	Zero Framing Projector 28	<b>RR73</b> ○	<b>BC53</b>	4.8	470 lm	<b>BS</b> (11°-32°)	<b>D1</b> 0-10V Dim <b>30</b> 3000K
	Zero Framing Projector 38	<b>RR56</b> ○	<b>BC42</b>	9.7W	922 lm	<b>BS</b> (14°-35°)	<b>DC*</b> CASAMBI <b>35</b> 3500K
		<b>RR71</b> ○				<b>DA*</b> Dali Dim <b>40</b> 4000K <b>DP*</b> Phase Dim	

\* Dimming Options Dali Dim (DA), CASAMBI (DC) and Phase Dim (DP) are available for Zero Framing Projector 38 only.  
BS: Beam Shaping.

# Zero Framing Projector

Track

- 10 - Black
- 11 - White

Advanced, multi-functional LED track mounted projector, tiltable vertically 0°-90° and rotatable horizontally 350°. With built-in bidirectional zooming lens with sharpness adjustability, and lens rotation.

Adjustable shutters to re-frame the beam to the desired size and shape (circle, square/rectangle, or irregular four-sided shapes). Compatible with Gobo insertion for logo.

High-precision optics for sharp outlines and high degree of lighting uniformity.

For complete code ordering information, please see page 35.

**LED Sources:**

High Rendering:  
CRI: 97 | CCT: 2700K, 3000K, 3500K, 4000K.

**Accessories:**

- Gobo Film, see page 15 for details
- Contact us for custom-made logo projection lens.



## Zero Framing Projector Track



10 11



6643

6640

6641

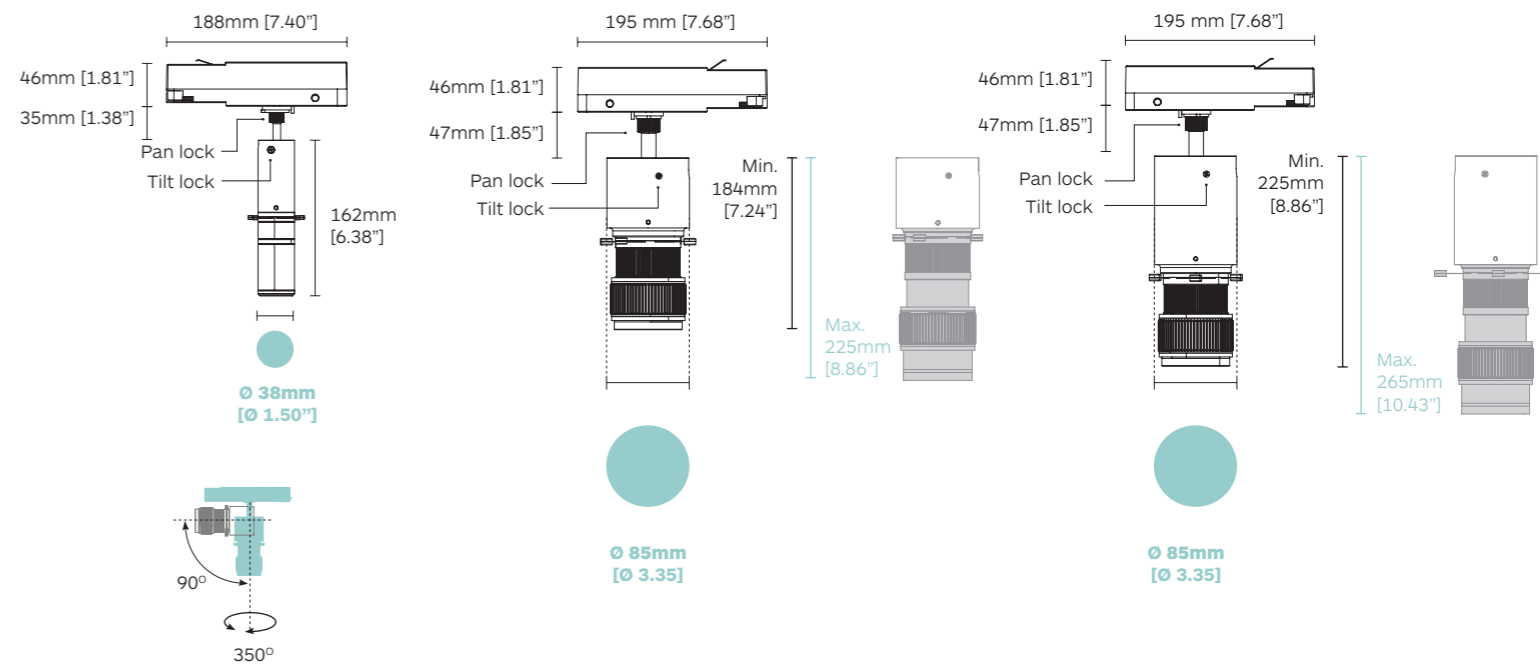

**CRI > 97**  
**3000K**  
**High Rendering**

Product Code	LED Source Code	LED Power	Nominal Lumen	Beam Angle	Dimming Options	CCT Options
Zero Framing Projector 38	<b>6643</b>	<b>BC42</b>	9.6W	922 lm	<b>BS</b> (14°-35°)	<b>27</b> 2700K
Zero Framing Projector 85	<b>6640</b>	<b>BC39</b>	18W	1937 lm	<b>BS</b> (13°-23°) <b>BW</b> (23°-35°)	<b>30</b> 3000K <b>35</b> 3500K
	<b>6641</b>	<b>BC39</b>	26W	2656 lm	<b>BS</b> (13°-23°) <b>BW</b> (23°-35°)	<b>40</b> 4000K

**BS:** Beam Shaping; **BW:** Beam Wide.

# Zero Framing Projector

EVO 48V Track

- 10 - Black
- 11 - White

**LED Sources:**

High Rendering:  
CRI: 97 | CCT: 2700K, 3000K, 3500K, 4000K

**Accessories:**

- Gobo Film, see page 15 for details.
- Contact us for custom-made logo projection lens.



Zero 38 framing projector is an advanced, multi-functional EVO 48V track-mounted projector, tiltable vertically 0°-90° and rotatable horizontally 360°. With built-in bidirectional zooming lens with sharpness adjustability, and lens rotation. Available in regular and long arm version for deep recessed and pendant EVO 48V track.

Fully adjustable shutters to reframe the beam to the desired size and shape (circle, square/rectangle, or irregular four-sided shapes). Compatible with Gobo insertion for logo. High-precision optics for sharp outlines and a high degree of lighting uniformity.

For complete code ordering information, please see page 35.

# Zero Framing Projector EVO Track



Regular Arm + EVO Regular Track

Long Arm + EVO Deep Track

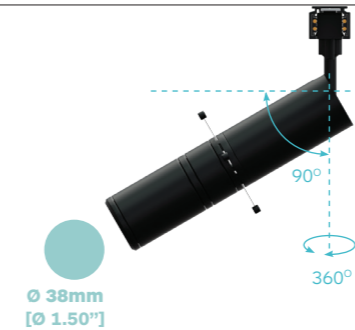
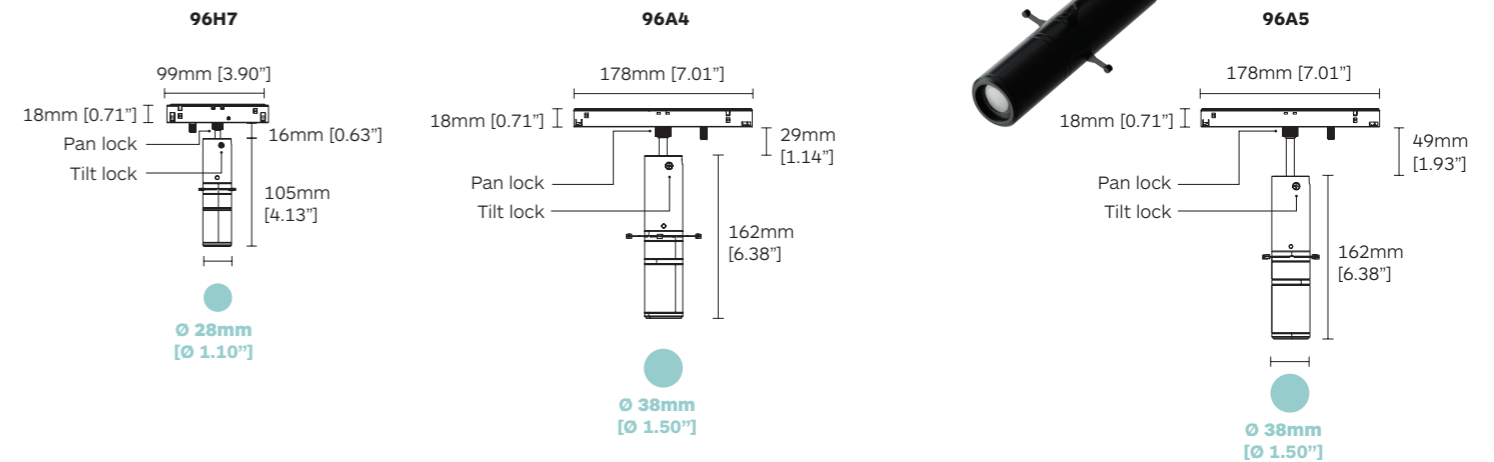

Regular Arm + Regular Track

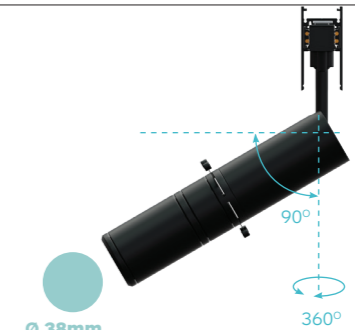

Long Arm + Deep Track

	Product Code	LED Source Code	LED Power	Nominal Lumen	Beam Angle	Dimming Options	CCT Options
<b>CRI &gt; 97</b> <b>3000K</b> <b>High Rendering</b>	Zero Framing Projector 28	<b>96H7</b>	<b>BC53</b>	4.8	470 lm	<b>BS</b> (11°-32°)	<b>27</b> 2700K
	Zero Framing Projector 38	<b>96A4</b>	<b>BC42</b>	9.7W	922 lm	<b>BS</b> (14°-35°)	<b>30</b> 3000K
	Zero Framing Projector 38 Long Arm	<b>96A5</b>				<b>DA</b> Dali Dim	<b>35</b> 3500K
						<b>DN</b> On Board Dimmer	<b>40</b> 4000K

BS: Beam Shaping.

# Zero Framing Projector

## Micro Track

Advanced, multi-functional LED track-mounted projector, tiltable vertically 0°-90° and rotatable horizontally 350°. With built-in bidirectional zooming lens with sharpness adjustability, and lens rotation. Adjustable shutters to re-frame the beam to the desired size and shape (circle, square/rectangle, or irregular four-sided shapes).

Compatible with gobo insertion for the logo. High-precision optics for sharp outlines and high degree of lighting uniformity.

For complete code ordering information, please see page 35.

### LED Sources:

High Rendering:  
CRI: 97 | CCT: 2700K, 3000K, 3500K, 4000K.

### Accessories:

- Gobo Film, see page 15 for details. Contact us for custom-made logo projection lens.

10 - Black

11 - White

# Zero Framing Projector Micro Track

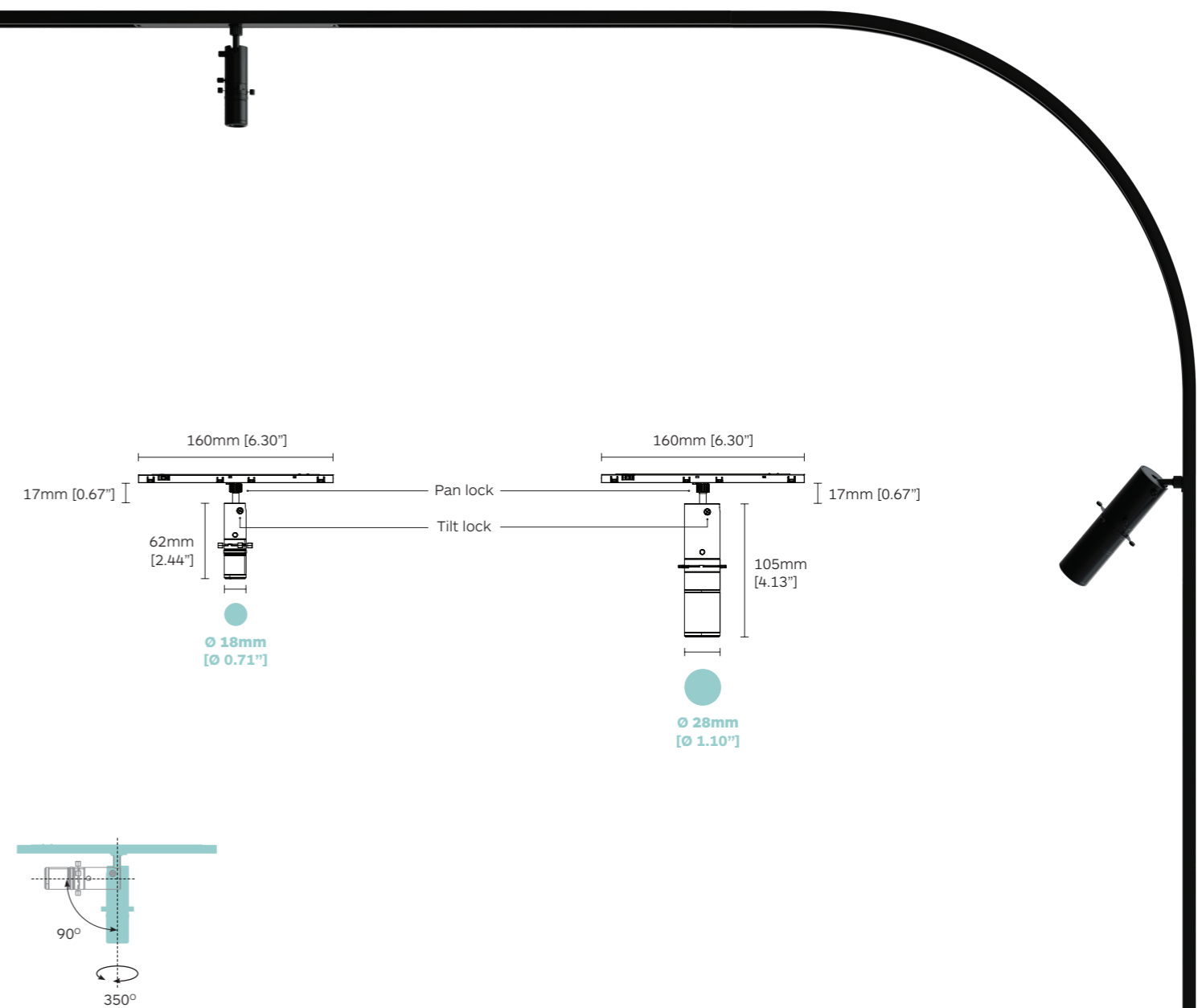

	Product Code	LED Source Code	LED Power	Nominal Lumen	Beam Angle	Dimming Options	CCT Options
<b>CRI &gt; 97</b> <b>3000K</b> <b>High Rendering</b>	Zero Framing Projector 18	<b>T674</b>	<b>BC52</b>	2.4	205 lm	<b>BS</b> (15°-33°)	<b>27</b> 2700K
	Zero Framing Projector 28	<b>T650</b>	<b>BC53</b>	4.8	470 lm	<b>BS</b> (11°-32°)	<b>30</b> 3000K <b>35</b> 3500K <b>40</b> 4000K

BS: Beam Shaping.

# Zero Framing Projector

Mini Track

- 10 - Black
- 11 - White

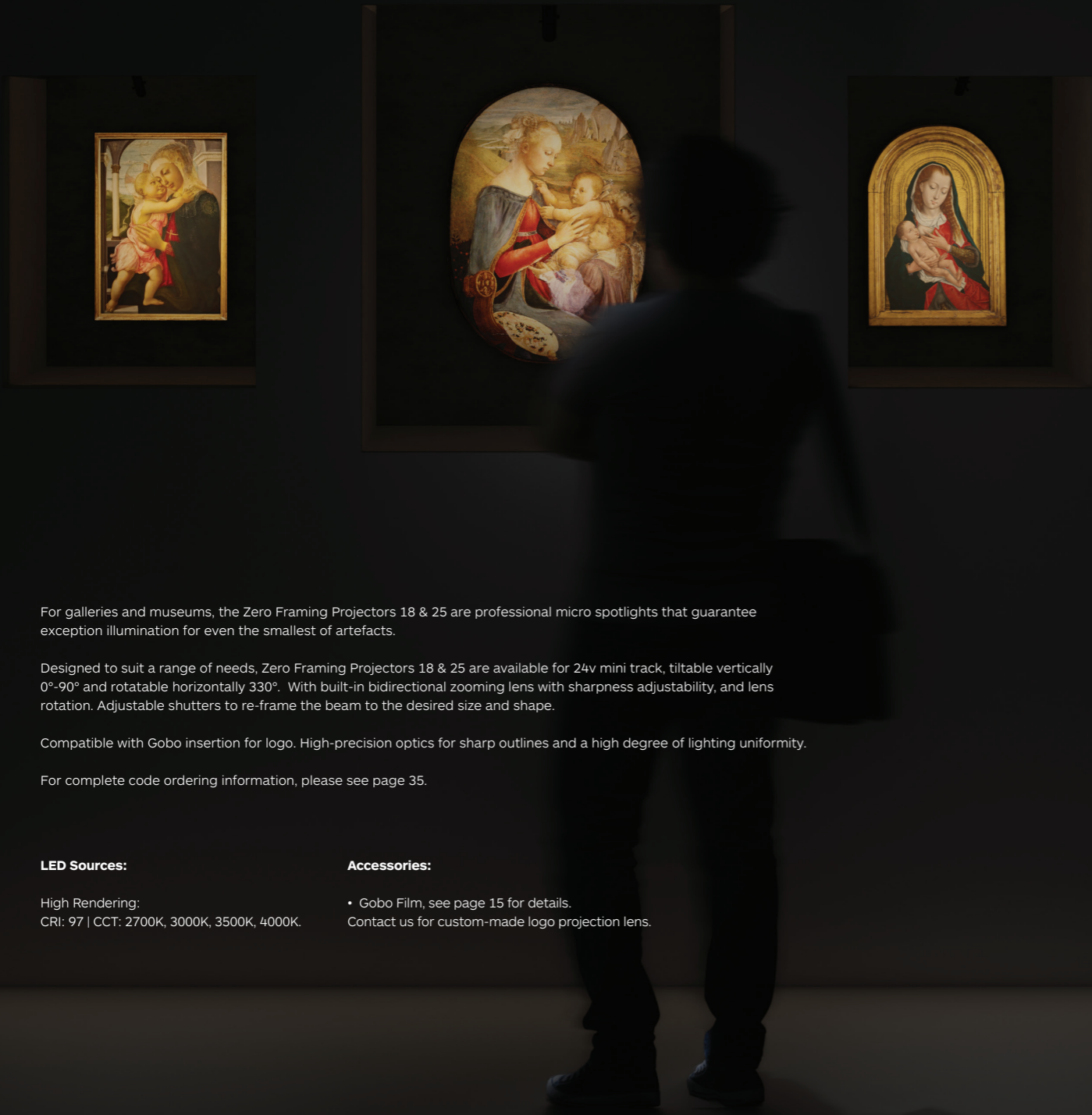

For galleries and museums, the Zero Framing Projectors 18 & 25 are professional micro spotlights that guarantee exception illumination for even the smallest of artefacts.

Designed to suit a range of needs, Zero Framing Projectors 18 & 25 are available for 24v mini track, tilttable vertically 0°-90° and rotatable horizontally 330°. With built-in bidirectional zooming lens with sharpness adjustability, and lens rotation. Adjustable shutters to re-frame the beam to the desired size and shape.

Compatible with Gobo insertion for logo. High-precision optics for sharp outlines and a high degree of lighting uniformity.

For complete code ordering information, please see page 35.

**LED Sources:**

High Rendering;  
CRI: 97 | CCT: 2700K, 3000K, 3500K, 4000K.

**Accessories:**

- Gobo Film, see page 15 for details. Contact us for custom-made logo projection lens.

# Zero Framing Projector Mini Track

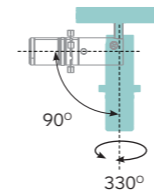
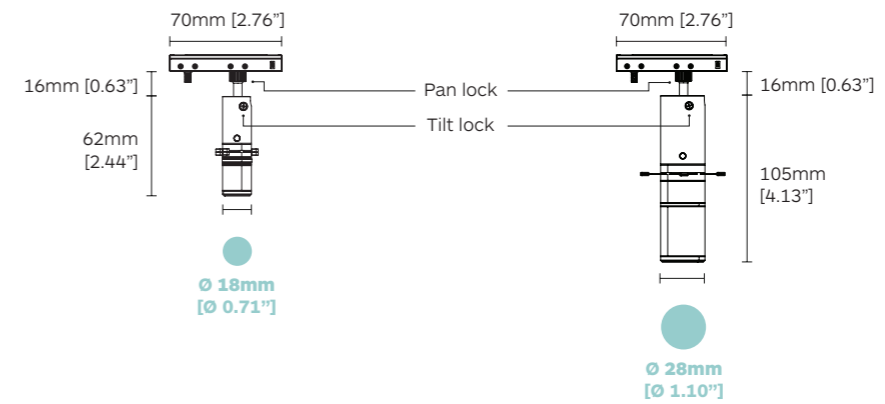
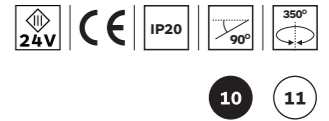

	Product Code	LED Source Code	LED Power	Nominal Lumen	Beam Angle	Dimming Options	CCT Options	
<div style="background-color: #008080; color: white; padding: 2px;">CRI &gt; 97 3000K</div> <b>High Rendering</b>	Zero Framing Projector 18	<b>G96C</b>	<b>BC52</b>	2.4	205 lm	<b>BS</b> (15°-33°)	<b>D0</b> No Dim	<b>27</b> 2700K
	Zero Framing Projector 28	<b>G96D</b>	<b>BC53</b>	4.8	470 lm	<b>BS</b> (11°-32°)	<b>D1</b> 0-10V Dim	<b>30</b> 3000K <b>35</b> 3500K <b>40</b> 4000K

**BS:** Beam Shaping.

# Zero Framing Projector

Surface 38 | 85

10 - Black

11 - White



Advanced, multi-functional LED surface-mounted projector, tilttable vertically 0°-90° and rotatable horizontally 350°. With built-in bidirectional zooming lens with sharpness adjustability, and lens rotation. Available in 38mm and 85mm. Adjustable shutters allow you to re-frame the beam to the desired size and shape.

Compatible with gobo insertion for the logo. High-precision optics for sharp outlines and a high degree of lighting uniformity.

For complete code ordering information, please see page 35.

### LED Sources:

High Rendering:  
CRI: 97 | CCT: 2700K, 3000K, 3500K, 4000K.

### Accessories:

- Gobo Film, see page 15 for details. Contact us for custom-made logo projection lens.

## Zero Framing Projector 38 & 85 Surface

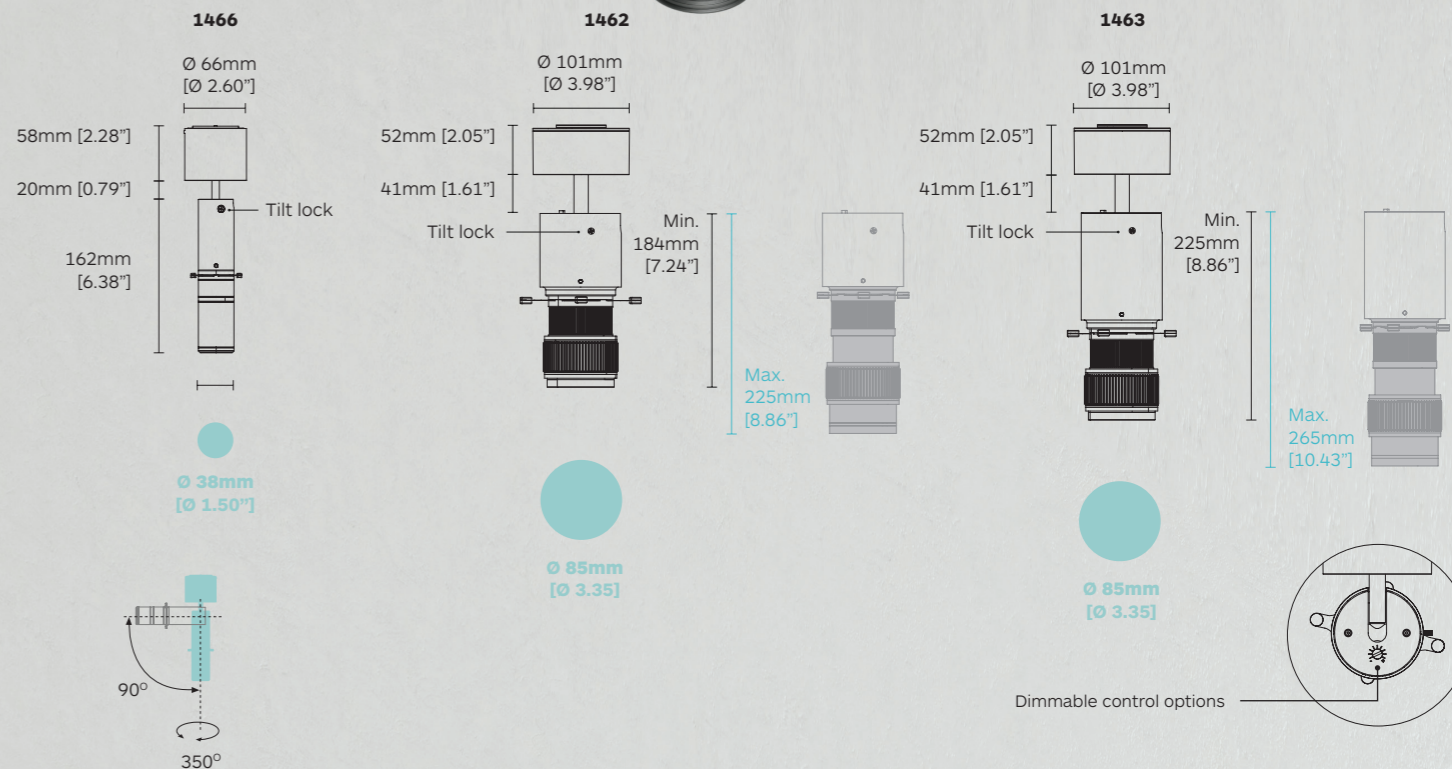

	Product Code	LED Source Code	LED Power	Nominal Lumen	Beam Angle	Dimming Options	CCT Options
CRI > 97 3000K High Rendering	Zero Framing Projector 38	1466	BC42	9.6W	922 lm	BS (14°-35°)	27 2700K
	Zero Framing Projector 85	1462	BC39	18W	1937 lm	BS (13°-23°)	30 3000K
						BW (23°-35°)	35 3500K
		1463	BC39	26W	2656 lm	BS (13°-23°)	40 4000K
						BW (23°-35°)	

\* Dimming Options On Board Dimmer (DN) is available for Zero Framing Projector 85 only.  
BS: Beam Shaping; BW: Beam Wide.

# Zero Framing Projector

Surface 18 | 28



The compact surface-mounted projector works with a low-voltage power supply. Tilttable vertically 0°-90° and rotatable horizontally 350°. With a built-in bidirectional zooming lens with sharpness adjustability, and lens rotation. Available in 28mm and 18mm. Adjustable shutters allow you to re-frame the beam to the desired size and shape.

- 10 - Black
- 11 - White

Compatible with gobo insertion for the logo. High-precision optics for sharp outlines and a high degree of lighting uniformity. An ultra-compact design ideal for showcase and display lighting applications.

For complete code ordering information, please see page 35.

**LED Sources:**

High Rendering:  
CRI: 97 | CCT: 2700K, 3000K, 3500K, 4000K.

**Accessories:**

- Gobo Film, see page 15 for details.
- Contact us for custom-made logo projection lens.

## Zero Framing Projector 18 & 28 Surface

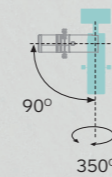
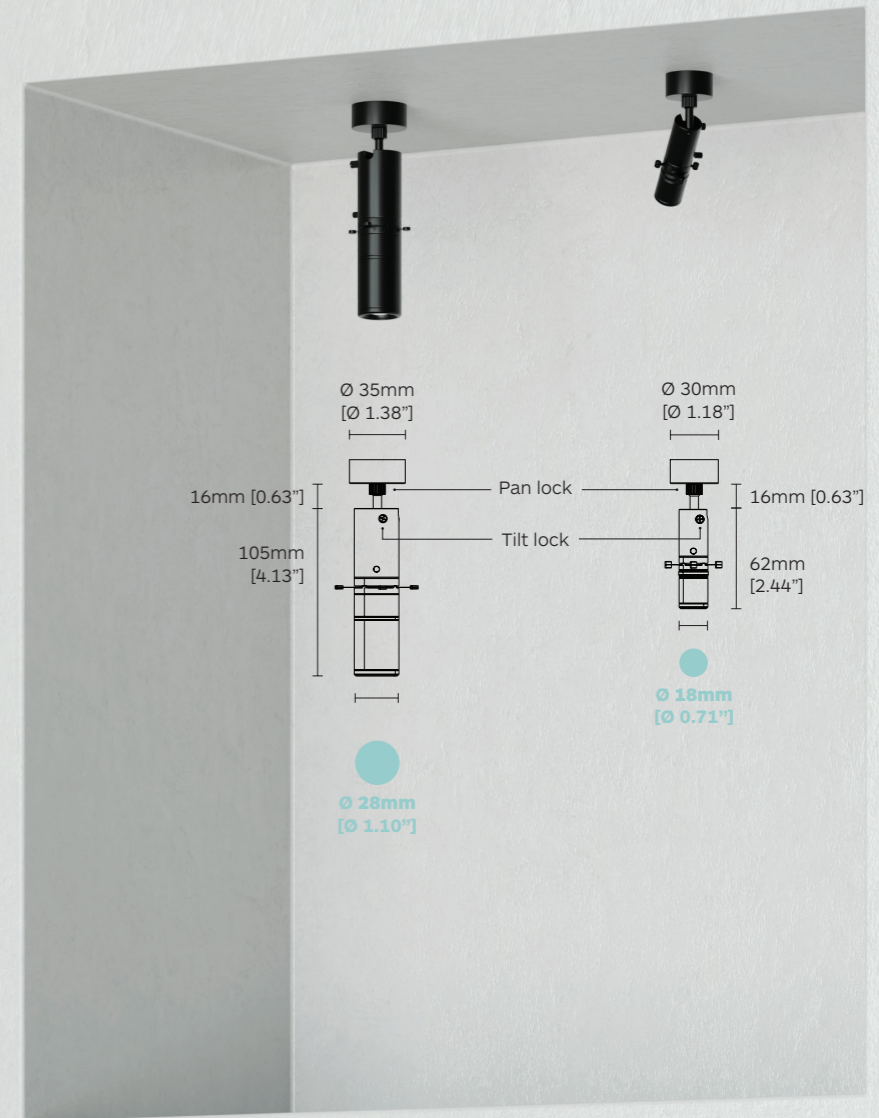

	Product Code	LED Source Code	LED Power	Nominal Lumen	Beam Angle	Dimming Options	CCT Options
<b>CRi&gt;97</b> <b>3000K</b> High Rendering	Zero Framing Projector 18	<b>1491</b>	<b>BC52</b>	2.4	205 lm	<b>BS</b> (15°-33°)	<b>D0</b> No Dim
	Zero Framing Projector 28	<b>1492</b>	<b>BC53</b>	4.8	470 lm	<b>BS</b> (11°-32°)	<b>D1*</b> 0-10V Dim
							<b>27</b> 2700K
							<b>30</b> 3000K
							<b>35</b> 3500K
							<b>40</b> 4000K

\* Dimming Options 0-10V Dim (**D1**) available via external Drivers.  
**BS:** Beam Shaping.

**Symbols & Icons**  
**Code system**  
**Global presence**

## Symbols & Icons

Trim Round 

Round ceiling cut 

CE Mark - Product complies with CE Standard. 

CSA Mark - Product complies with USA & Canada Standard. 

**CLASS I**  
Luminaires of insulation Class I - with earth connector. 

**CLASS II**  
Luminaires of insulation Class II - With safety isolation, this means the tension conduction element are protected by additional isolation. The isolation of an earth wire it is not necessary and the connection to it is not allowed. 

**CLASS III**  
Luminaires of insulation Class III - designed for operation of protected low voltage supply (>42V). 

48V input integrated. 

24V input integrated. 

CASAMBI 

Recyclable 

## IP\_\_ Degree of Ingress Protection

1st Number	Protection Against Dust and Solid Objects	2nd Number	Protection Against Moisture and Liquids
0	No-Protection	0	No-Protection
1	Protection against solid objects >50 mm	1	Protection against dripping water
2	Protection against solid objects >12 mm	2	Protection against dripping water tilted > 15 deg
3	Protection against solid objects >2.5 mm	3	Protection against spraying water > 30 deg
4	Protection against solid objects >1 mm	4	Protection against spraying water
5	Dust - protected	5	Protection against water jet
6	Dust - tight	6	Protection against waves
		7	Protection against the effects of immersion
		8	Protection against submersion

## Body Color

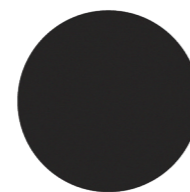

10 Black (RAL 9004)



11 White (RAL 9003)

## Code System

Code ordering example: **G 9 6 D B C 5 3 - 9 7 3 0 B S D 0 1 1**

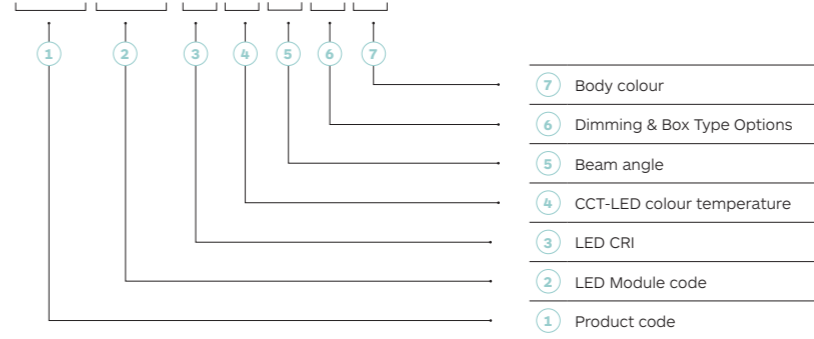

LED CRI	CCT-LED Colour temperature	Dimming Options	Body Colour
<b>97</b> CRI > 97	<b>27</b> Warm White 2700K	<b>D0</b> No Dim	<b>10</b> Black (RAL 9004)
	<b>30</b> Warm White 3000K	<b>D1</b> 0-10V Dim	<b>11</b> White (RAL 9003)
	<b>35</b> Warm White 3500K	<b>DA</b> Dali Dim	
	<b>40</b> Warm White 4000K	<b>DC</b> CASAMBI	
		<b>DN</b> On Board Dimmer	
		<b>DP</b> Phase Dim	

## How to order

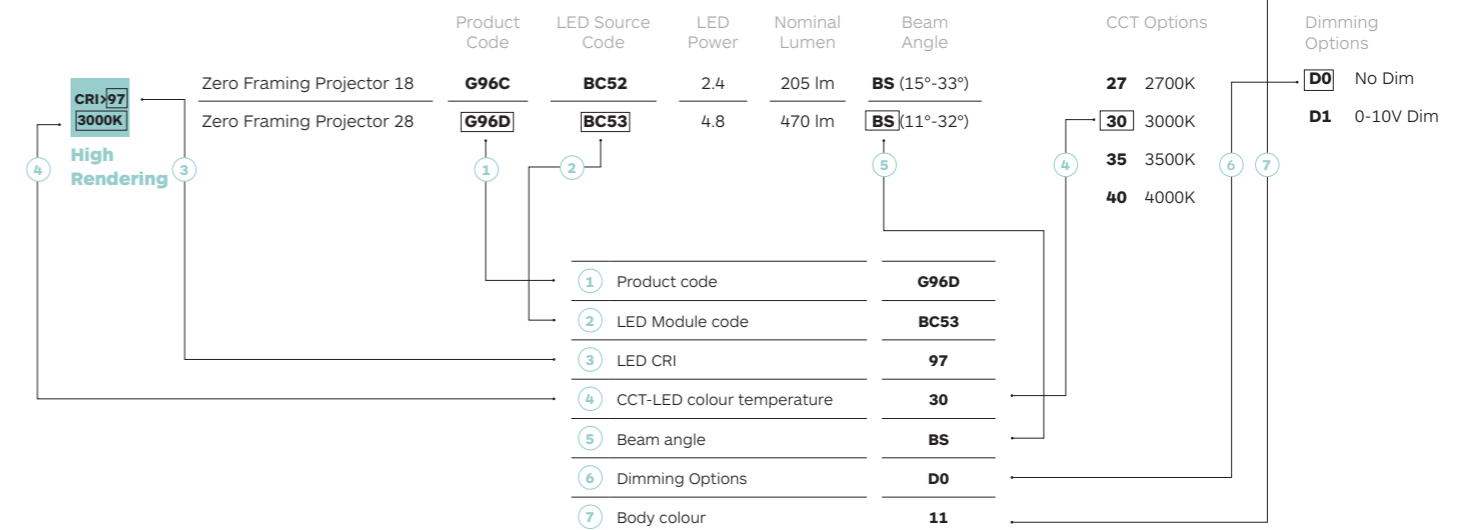

# Global presence

Celebrating over 50 years of vision, dedication and innovation, formalighting's versatile and high-quality product offerings extends internationally via our headquarters in Hong Kong, London, Milan and Shanghai.

Our well chosen and selected partners as well as our affiliated international offices broaden our global presence further in markets such as USA, Australia, Japan, South East Asia, India and the Middle East.

Through our commitment to growth and investment within formalighting's professional team, infrastructure and product ranges, we are able to provide increasing service to our global retail and hospitality clients as well as lighting designers and specifiers strengthening our position as a leading international supplier of innovative architectural lighting solutions and systems.

With over 50 years' experience in designing and manufacturing architectural lighting, formalighting's comprehensive portfolio offers a competitive range of European designed and expertly engineered products that carry CB, CE, CCC and UL certifications.

Furthermore formalighting's latest award-winning motorized range of track, pendant, and recessed fixtures, featuring remote-controlled adjustable pan and tilt, dim, dim to warm, tuneable white and beam shaping lens, are available worldwide incorporating the latest, most advanced lighting technologies.

## MILAN

### EUROPE HEADQUARTERS

Tel ( +39 ) 02 9354 0300

Fax ( +39 ) 02 9343 5117

E- mail info-europe@formalighting.com

## HONG KONG

### ASIA HEADQUARTERS

Tel ( +852 ) 2516 6500

Fax ( +852 ) 2516 6525

E- mail info-asia@formalighting.com

## NEW YORK

### LOCAL SALES OFFICE

E- mail info-us@formalighting.com

## SHANGHAI

### LOCAL SALES OFFICE

E- mail info-china@formalighting.com

## LONDON

### LOCAL SALES OFFICE

E- mail info-uk@formalighting.com

## AUSTRALIA

### LOCAL SALES OFFICE

Tel ( +61 ) 488 567 388

E- mail info-australia@formalighting.com

## INDIA

### LOCAL SALES OFFICE

Tel ( +91 ) 9686351257

E- mail info-india@formalighting.com

formalighting is constantly developing and improving its products therefore all information, drawings illustrations, specifications, photometric values in this catalogue are indicatives and shall not form part of any commitment by our company that reserves the right to change specifications without prior notification or public announcement. Technical information on the installation-instruction has precedence over the information in the catalogue.

Our general terms and conditions shall apply notwithstanding any stipulation on the contrary to all the orders and agreement with formalighting. You can obtain a copy of these conditions on demand.

Publication date: March 2026

©Copyright formalighting

With thanks to all contributors for the realization of this catalogue

Designed by formalighting's Graphic Design Department

No part of this catalogue may be copied without written authorization of formalighting



Zero Framing Projector Series 2026

formalighting

MILAN

-

LONDON

-

USA

-

HONG KONG

-

SHANGHAI

-

INDIA